

UNISON



BLACK WIDOW 150

All Terrain Vehicle (ATV)

Welcome to the growing family. This vehicle is delivered to you with the confidence and the reliability that have made us stand out in these fields.

This vehicle is designed and manufactured for **OFF-ROAD** use only, please check your local riding laws and regulations before operating this machine.

Read this manual together with your children. It is important that you take the time to get acquainted with how your ATV works. The user manual provides detailed **safety instructions, operation** and **maintenance** procedures.

An ATV is not a toy and can be hazardous to operate without proper instructions, we highly recommend that you take a training course from a certified instructor.

Please follow the age recommendation:

ATV Size / Minimum Age

150cc: 16 years and older

Please pay close attention to the following labels:



**ALWAYS USE APPROVED
HELMET AND
PROTECTIVE GEAR**



**NEVER USE ON PUBLIC
ROADS**



**NEVER CARRY
PASSENGERS**



**NEVER USE WITH
DRUGS OR
ALCOHOL**

Specifications- DN/DS/FB 150cc

Engine Type:	4 Stroke Horizontal	Suspension Rear:	Swing Arm
Max. Power:	10ps / 6500 rpm	Brake Front & Back:	Drum / Disk
Cylinder No#	1	Front & Rear Tire:	20 x 6-10 / 18 x10.5-8 & 21x 7-10 / 21 x10-10
Bore Stroke:	57.2 x 58.4mm	Transmission:	Automatic (C.V.T.)
Displacement:	150cc	Fuel:	Unleaded Gasoline
Max. Torque:	10.4N-m / 4500 rpm	Overall Dimension:	62.3" x 41.7" x39.4" (1600mm x1060mm x 1000mm)
Carburetor:	Mikuni	Wheelbase:	45.2" (1150mm)
Starting:	Electric & Kicker	Seat Height:	31.5" (800mm)
Lubricate:	Oil pump	Ground Clearance:	7.9" (200mm)
Lubricate Capacity:	1 Liter	Dry Weight:	308lbs (140kg)
Suspension Front:	Double A-arm	Max. Load:	330 lbs (150kg)

Understand your ATV and specifications (DN/DS/FB 150cc)

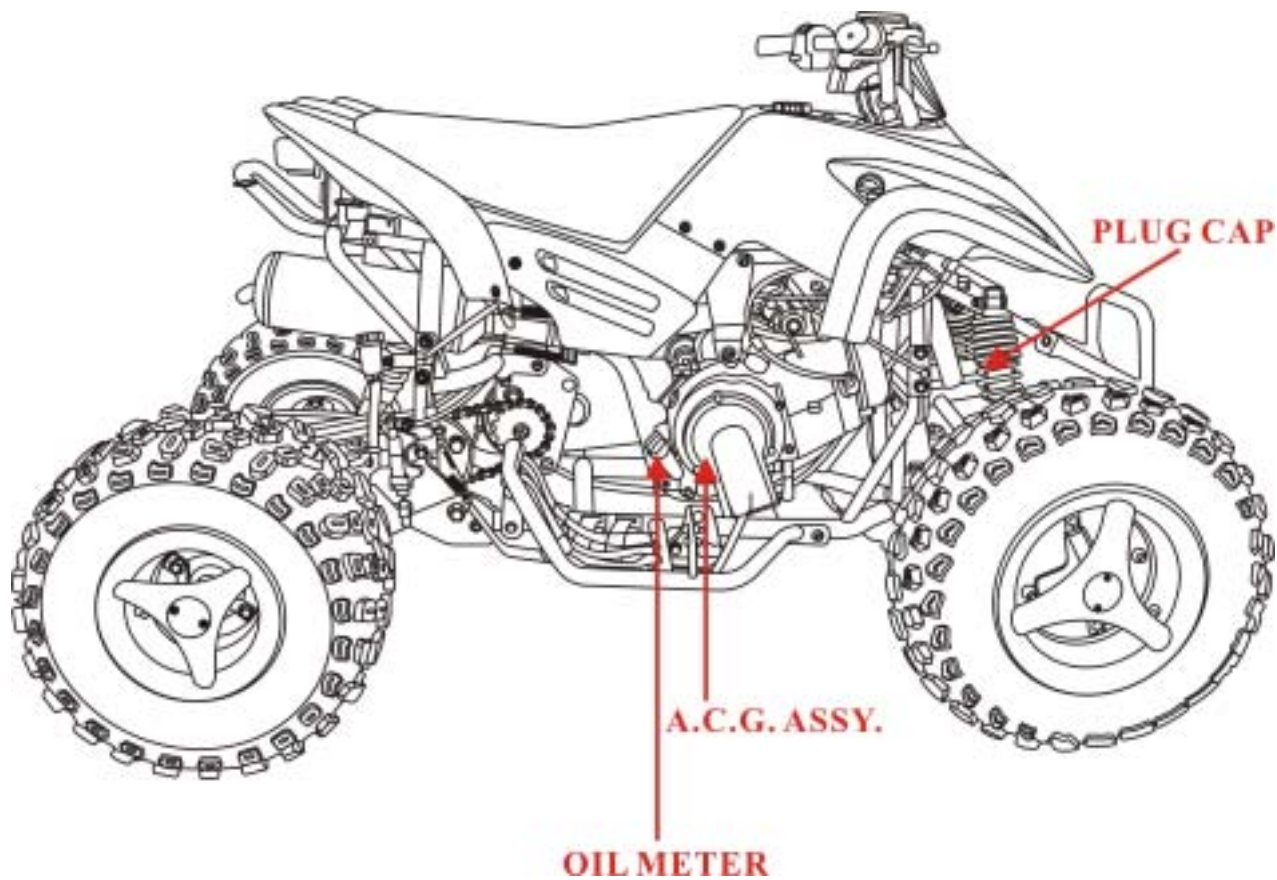

ATV Parts locations and specifications (DN/DS/FB 150cc)

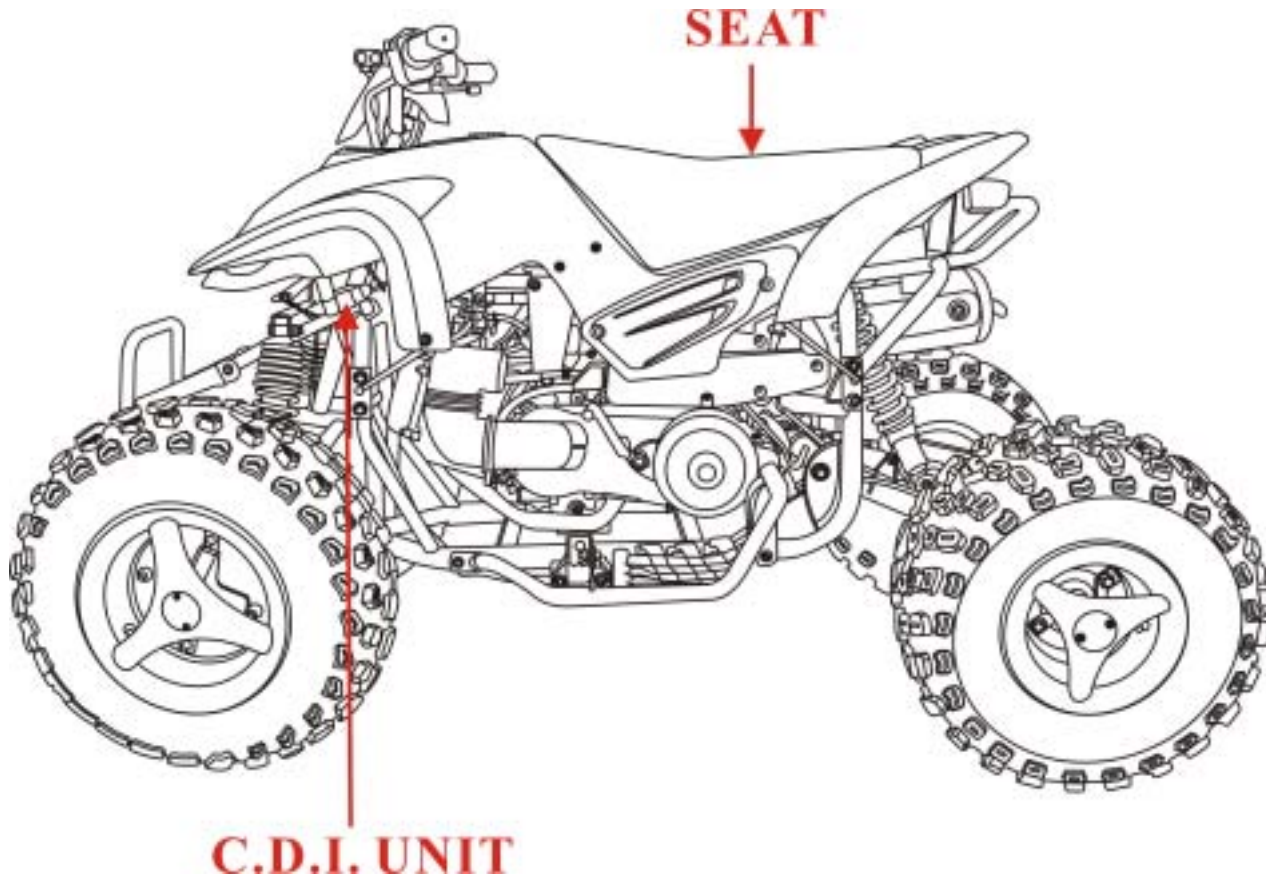

ATV Parts locations and specifications (DN/DS/FB 150cc)

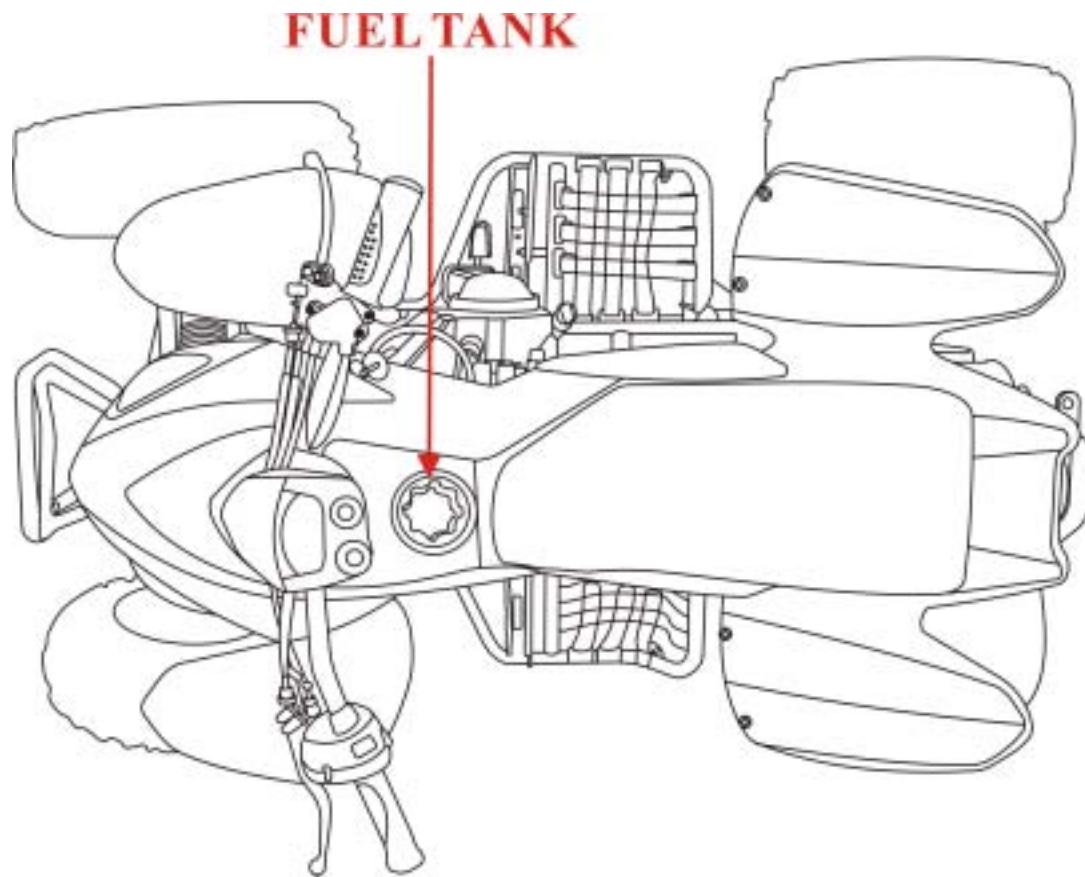

Are You Ready?



Important Information



- **Before you ride your ATV, we urge you to read and do the followings:**
- Always follow the age recommendation for the ATV.
- Do not allow your child to ride without adult supervision.
- This vehicle is not designed for carrying a passenger. Carrying passengers can cause loss of control resulting in severe injury or death. This vehicle is properly balanced to carry only the operator.
- Never operate without wearing an approved motorcycle helmet that fits properly. We urge you to wear eye goggles, face shield, gloves, boots, long-sleeved shirt or jacket and long pants.
- Never use with drugs or alcohol before or while operating this vehicle.
- Never operate an ATV on any public street, road, and highway. Try to avoid on any paved surfaces, including sidewalks, driveways, and parking lots.
- Never operate at speeds faster than your skill, or attempt any stunts. This can result in severe injury.
- Never modify an ATV through improper installation or use of accessories.
- Always use the size and type of tires specified in this manual. Always maintain proper tire pressure as described in this manual.
- Please inspect your ATV each time before use, and make sure it is in safe operating condition.
- Always follow the maintenance procedures.
- Read the warranties thoroughly so you understand the coverage that protect your new ATV and are aware of your rights and responsibilities.
- Always turn off the engine when refueling.
- Do not refuel when the engine is hot or running. Do not spill gasoline on the engine or the exhaust pipe, muffler.
- Never refuel while smoking, and do not use the cellular phone while riding you ATV.

An ATV handles differently from other vehicles, including motorcycles and cars. A collision or rollover can occur quickly, even during routine maneuvers such as turning and driving on hills and over obstacles, if you fail to take proper precautions.

Are You Ready?



Important Information



- If you have any questions, or if you ever need special service or repairs, remember that your source dealer knows your ATV the best and is dedicated to your complete satisfaction.
- Never remove any labels from your ATV. If a label becomes difficult to read or comes off, a replacement label is available from your dealer.
- Never run the engine in close areas. The exhaust gas contains poisonous carbon monoxide.
- Do not touch any part of the engine, muffler or exhaust system while the ATV is still hot.
- Never attempt to operate over large obstacles, such as large rocks or fallen trees. Always check for obstacles before operating in a new area.
- Never operate an ATV in fast flowing water or in water deeper than recommended in this manual. Remember that wet brakes may reduce stopping ability. Test your brakes after leaving water. If necessary, apply them several times to let friction dry out the linings.
- When transporting the machine in another vehicle, be sure it is kept upright and that the fuel cock is in the “OFF” position. Otherwise, fuel may leak out of the carburetor or fuel tank.
- Always be careful when skidding or sliding. Learn to safely control skidding or sliding by practicing at low speeds and on level smooth terrain. On extremely slippery surfaces such as ice, go slowly and be very cautious in order to reduce the chance of skidding or sliding out of control.
- ATV handles differently from other vehicles, including motorcycles and cars. A collision or rollover can happen quickly and even routine maneuvers, turning, driving on hills or down hills and over obstacles, if you fail to take proper precautions, it can result in serious injury or death. Be cautious when riding and check your ATV each time before taking off, always have emergency first aid kit, tools with your ride.

Are You Ready?

Protective Apparel

- Never operate without wearing an approved motorcycle helmet that fits properly. You should also wear eye goggles, face shield, chest protector, gloves, boots, long-sleeved shirt or jacket and long pants.



Your helmet is the most important piece of protective gear, can help prevent a serious head injury. Your helmet should fit snugly and fasten securely. Select a helmet that meets or exceeds state's safety standards. Full face helmets help protect your face as well as your head.



Open face helmet are lighter and may be cooler, but should be used with eye and mouth protection.



Good padded gloves can help keep your hands from getting sore, cold or bruised.



Over-the-ankle boots with low heels can prevent your feet from slipping off the footrest and protect your feet, ankles and lower legs.

Is Your ATV Ready?



Always inspect your ATV before you ride, please follow the checklist, it decreases the possibility of an accident or equipment damage.

1. Fuel: Check the level, fill fuel if needed.
2. Engine Oil: Check oil level, fill oil if needed.
3. Wheels and Tires: Check tire pressure, wear or damage.
4. Switches: Check to make sure they are working properly.
5. Fittings and fasteners: Check all fittings and fasteners.
6. Brakes: Check operation, of cable or fluid level on front and rear brakes.
7. Parking Brakes: Check for smooth condition and operation.
8. Drive Chain: Check the tension of the chain and make sure there are no damaged or rusted links, and check on sprocket condition.
9. Always warm up the engine for at least 5 minutes before take off, never accelerate hard with a cold engine, it does damage to your engine life.

*** Apply chain lubricant to lubricate the drive chain.**

Break-In your ATV

Make sure all fluids have been filled (coolant, trans oil. etc.). Before starting a freshly rebuilt or new engine it is strongly recommended that you make sure that the carburetor has been thoroughly cleaned and fuel tank has been flushed clean. Fresh fuel/oil mixture has been used, air box has been cleaned and a new or freshly serviced air filter has been installed. Once the above steps have been completed, start your engine and follow the break-in procedure.

Break-In your ATV

During the first 3 months or within 1500km of riding, operate your new vehicle tenderly. Don't run it very fast and don't approach the maximum rpm.



Following these guidelines will greatly enhance the long-term power and life of the engine.

To get maximum engine life, always warm up the engine for at least 5 minutes before take off, never accelerate hard with a cold engine, it does damage to your engine life.

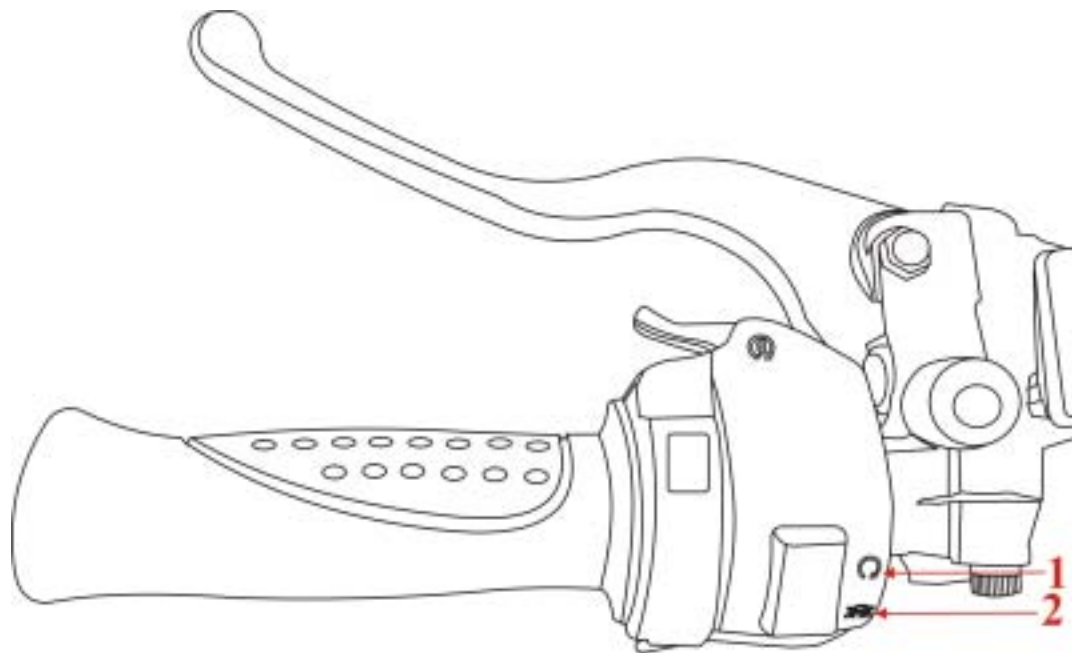
Engine On / Stop Switches (DN/DS/FB 150cc)



50cc/90cc/100cc Engine Stop Switch

The engine stop switch is on the left handle-bar. When the switch is in the “” position, the engine will OFF. When the switch is in the “” position, the engine will be ON. This switch also can be used as a safety or emergency switch.

1. On
2. Off

Starting Procedure (DN/DS/FB 150cc)

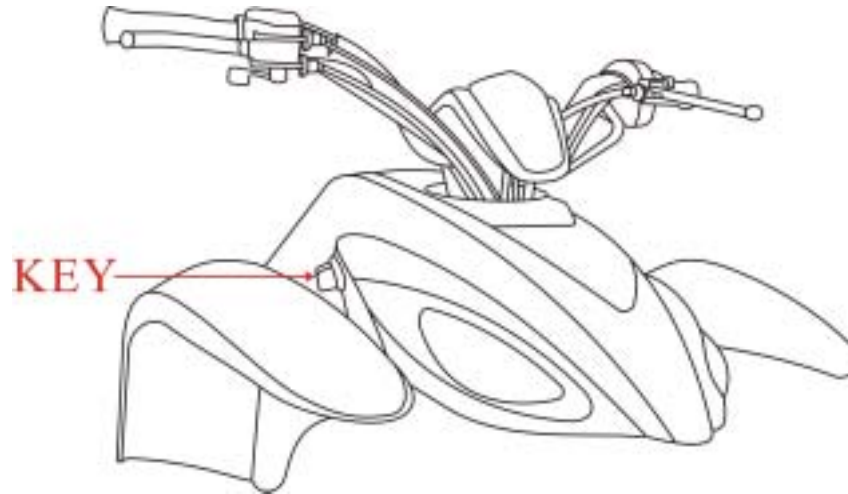

Starting Procedure

- Parking the vehicle on a level surface and lock the parking brake.
- Insert the ignition key into its switch and turn it to the “ON” position.
- Turn the fuel valve to.
- Move the engine stop switch to “ON “.
- Push the throttle level lightly.
- Push the start button on the left handle bar.

Throttle Lever (DN/DS/FB 150cc)

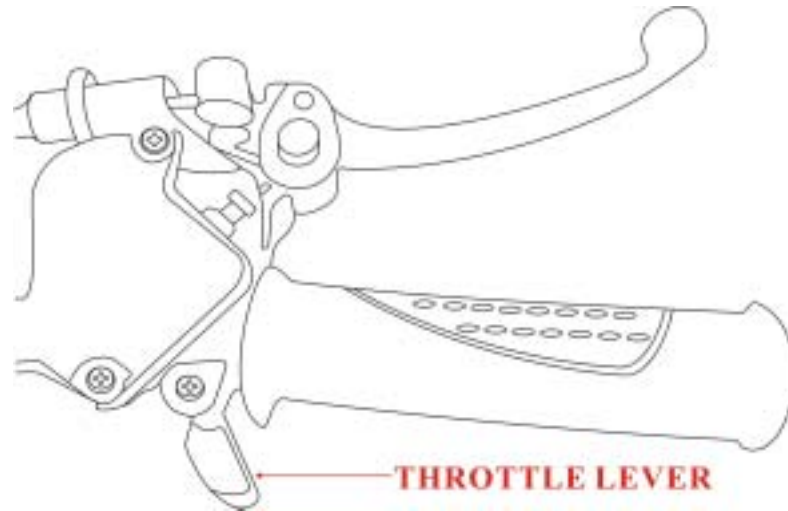

Throttle Lever

The throttle lever is beside the right handle bar grip and is activated by the right hand thumb. To accelerate the vehicle, simple press the lever forward and open the throttle, to decelerate, release the lever and the spring tension will close the throttle automatically.

Before starting the engine, check the throttle to be sure it can operate smoothly. Make sure it returns back to idle position as soon as the lever is released.

Front Brake & Rear Brake (DN/DS/FB 150cc)



Rear Brake

The rear brake is the lever located on the left handlebar. When braking, squeeze this lever. This brake also has a locking feature that allows it to act as a parking brake. To use the parking brake, pull the left-brake lever back and lock it. Make sure the vehicle is completely stopped before using the parking brake. To release the parking brake, firmly squeeze the left brake lever until the lock release.

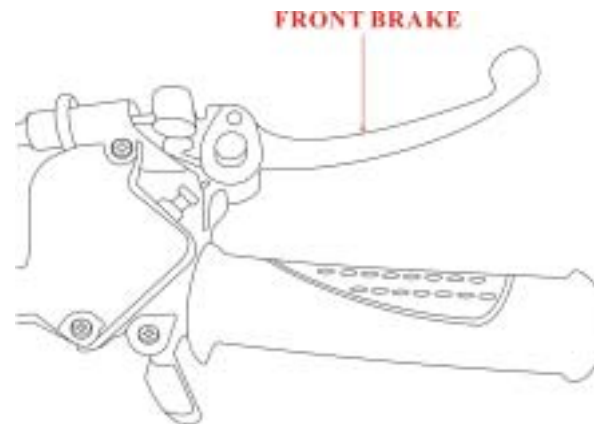

Front Brake

The front brake lever is located on the right handlebar, pull it towards you to apply the front brake.

Check your brakes at the start of every ride. Do not ride the ATV if you find any problem with the brakes. Please contact your local dealer to fix the problem.



Engine Oil

Engine Oil

We recommend that engine oil is changed per every 3 months or 1000km in the first time. Then check oil once a month, and if oil doesn't reach oil level, refill engine oil, please!!

Engine oil:SAE15W-40

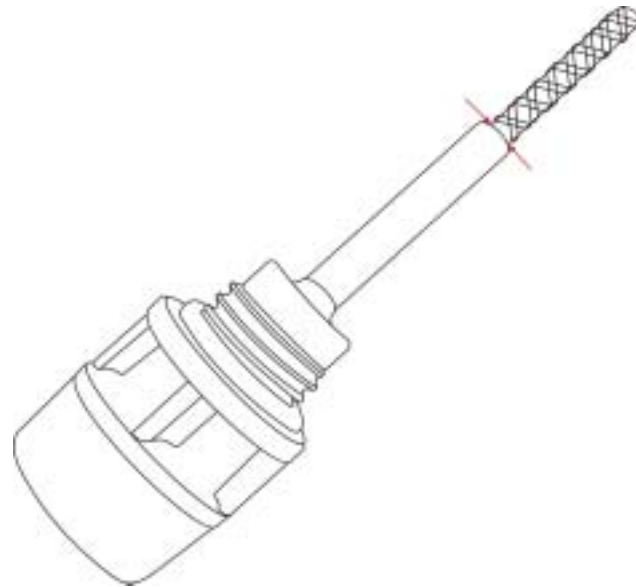

Fuel Valve & Fuel Tank

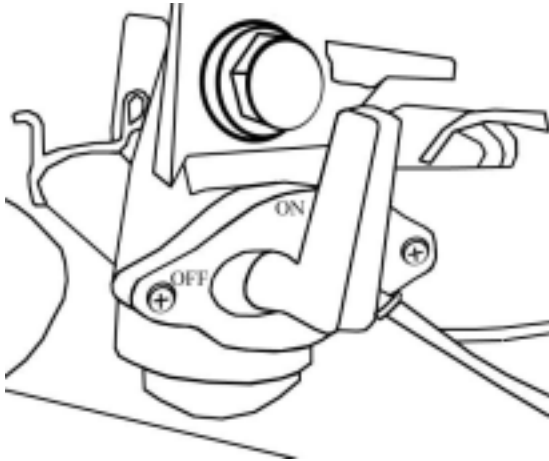

Fuel Valve

The three-way fuel valve is on the left side of the vehicle, just below the seat.

With the fuel valve set on the “**OFF**” position, gasoline cannot flow into the engine carburetor.

With the fuel valve set on the “**ON**” position, fuel will flow from the tank and go into engine.

With the fuel valve set on the “**RES**” position, fuel will flow from the reserve fuel supply to the engine. At this setting, the fuel tank should be refilled as soon as possible.

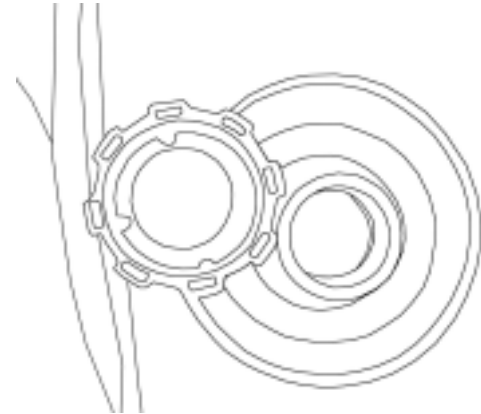

Fuel Tank

Fuel tank capacity is 12 liters (3 gallons).

Use only unleaded automotive gasoline with an octane level from 87, 89 or 91.

After refueling, be sure to tighten the tank cap firmly.



Do not overfill the fuel tank, be careful not to spill fuel, it can cause severe injury or fire. Turn off cellular phones and do not smoke when refueling. If overfill wipe off any spilled fuel immediately. Make sure the fuel tank cap is closed securely.



Tires Pressure

If the tire pressure is too high or too low, steering will be affected and tire wear will be increased.

Operating tire pressure: You should check the pressure before running the vehicle when the tires are cold.

•Recommended for 150cc:

Max. pressure: 10psi

Min. Pressure: 3psi



NOTE: Do not fill more than 10psi of pressure. Seal damage may occur.

• Never set tire pressure below minimum, it could cause the tire to dislocate from the rim.

Loading:

• Maximum vehicle load for the **150cc**: 190 lbs, includes weight of operator, cargo and accessories.

Under the seat

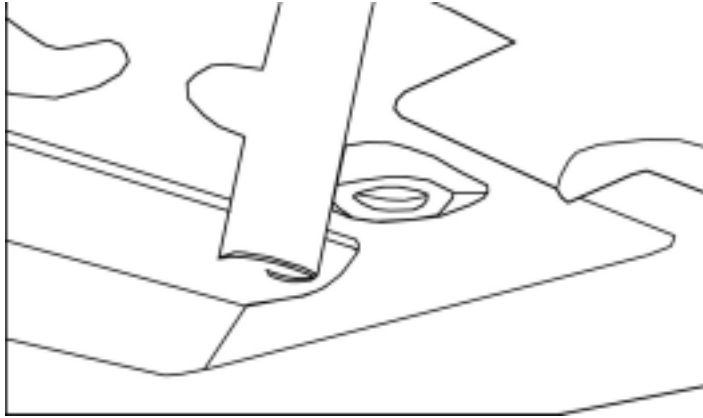

Remove the seat

Under the ATV seat there is a safety knob. Pull forward to remove the seat cover. You will be able to find the battery and tool kit.

Vehicle Identification Number (VIN) & Engine Number (DN/DS/FB 150cc)

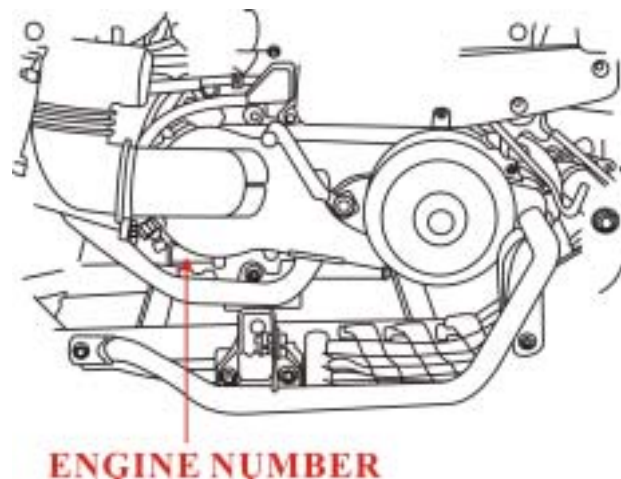
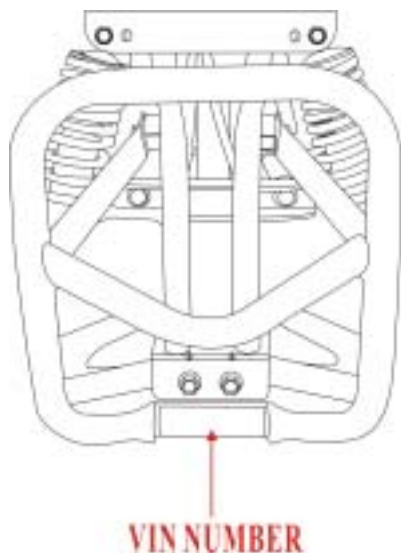

VIN Numbers

The frame, VIN and engine serial numbers are required when you register your ATV. They may also be required when ordering replacement parts.

Please record the frame and engine serial number for future reference.

Frame No. _____

Engine No. _____

Posture



- Head and eyes up, looking well ahead.
- Shoulder relaxed, elbows bent slightly out away from your body.
- Keep hand on the handlebars and wrists should always be straight.
- Knees toward the gas tank.
- Feet on the footboards during operation. Otherwise your feet may contact the rear wheels.
- Always keep your hands on the handlebars and foot on the footrest at all time.

Turning



The rider must learn to move his weight and control the throttle to allow the rear tires to turn properly. When turning, the wheels on the outside of the turn must travel a wider radius and thus a greater distance than the wheels on inside of the turn. Since the rear wheel axle does not permit a differing rate of wheel rotation, it is enough to merely steer this vehicle into a turn.

To turn properly, steer in the direction of the turn and lean your body to the inside of the turn while supporting your weight on the outer foot. Use the throttle to maintain power throughout the turn. Incorrect turning may cause the front wheels to slide straight ahead. If this should occur, close the throttle and stop. Avoid braking or accelerating until you have regained directional and speed control in order to avoid skids or while traveling on slippery terrain.

Riding Uphill

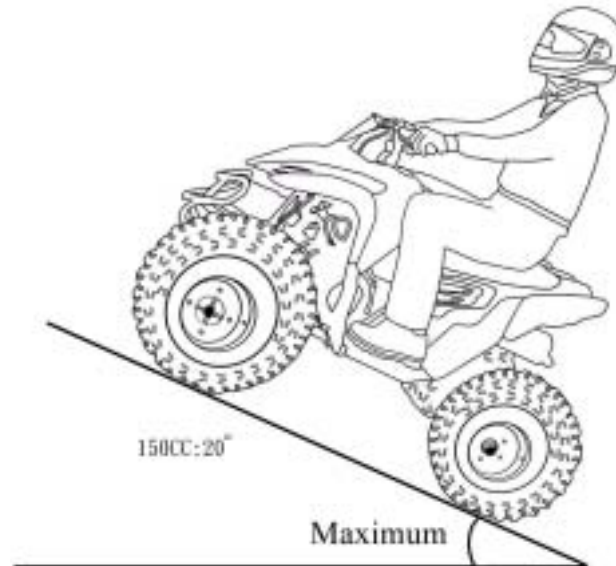

Uphill

- Practice riding at first on gentle slopes. Try more difficult hills only after developing and being comfortable with your basic skills.
- Avoid excessive steep hills or slopes, this could cause loss of control or the ATV to overturn.
- Keep both feet on the footrest at all times. When climbing a hill, shift your body weight forward at all times, proceed at a steady rate of speed and throttle opening.
- Never ride past the limit of your visibility. Slow down or stop. Proceed slowly only when you have a clear view.
- If you are unable to continue uphill, dismount the vehicle on the uphill side, turn the vehicle around and then descend the hill.
- If you cannot complete the hill due to steepness, do not engage the rear brake to stop from rolling backwards. This can easily tip the ATV backwards. Engage front brake and dismount the ATV. Only remount after turning the ATV around.

Riding Downhill



Downhill

- To go downhill, shift your body weight back, choose a low gear which will allow the engine compression to do most of the braking for you, improper braking may cause a loss of traction.
- Be cautious when going downhill with loose or slippery surfaces.
- Choose a straight down hill path and avoid obstacles.
- Avoid going down a hill at an angle.
- Use the brake(s) to slow you down as you going downhill and always use a low gear.
- Never go down a hill at high speeds. Always maintain control of speed.

Crossing A Slope



When you go across a slope rather than directly up or down, it's called traversing. Traversing a sloping surface on your ATV requires you to properly position your weight to maintain proper balance. Be sure that you have learned the basic riding skills on flat ground before attempting to cross a sloping surface.

- Lean your body uphill direction as you travel across a slope and keep both feet firmly on the footrests.
- When riding on the loose surfaces, you may need to turn your front wheel(s) gently uphill to keep straight line across the hill.
- Make sure not to attempt any sharp turns either up or downhill.
- If your ATV does begin to tip over, turn the front wheel(s) downhill direction if there are no obstacles in your path or dismount the ATV immediately!
- Avoid hills with excessively slippery or loose surfaces, it could cause loss of control or cause the ATV to over turn.

Crossing Through Shallow Water



The ATV can be used to cross slow moving, shallow water of up to maximum of 20cm in depth.

Before entering the water, choose your path carefully.

Enter where there is no sharp drop off, and avoid rocks or other obstacles which may be slippery or upset the ATV. Drive slowly and carefully.



Remember that wet brakes may have reduced stopping ability. Test your brakes after leaving water until you have regained proper braking ability.

Never operate this ATV in fast flowing water or in water deeper than specified in your manual book.

After riding in the water, be sure to drain the trapped water by removing the check hose at the bottom of the air filter case.

Wash the ATV in fresh water if it has been operated in salt water or muddy conditions.

Maintenance

Spark Plug

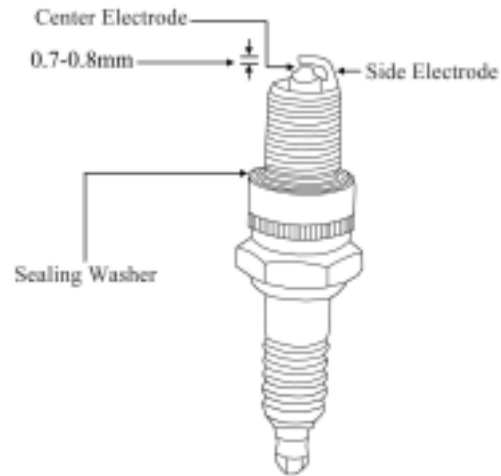

Spark Plug

Inspect spark plugs every other month for maximum efficiency. Replace when plugs are needed.

Standard spark plug: **C7HSA OR CR7HSA OR OTHER BRANDS / SPARKS (EECorCE)**

1. Disconnect the spark plug cap.
2. Clean up dirt from around the spark plug base.
3. Remove the spark plug.
4. Inspect the plug electrodes for wear. If the electrodes and insulator tip appear unusually fouled or burned, replace with new one.
5. The spark plug plug gap is 0.7 – 0.8mm. If adjustment is necessary, bend the side electrode carefully.
6. When Installing the spark plug, screw it in finger tight and then tighten with the plug wrench another ½ turn to compress the washer. Do not over tighten.

Maintenance

Air Filter



Air Filter

The air filter will accumulate dust and must be cleaned periodically. If riding in very dusty area, the filter must be cleaned more frequently.

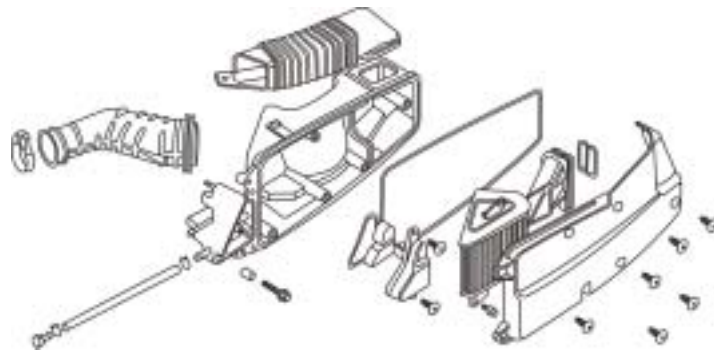

1. Remove dirty air filter from machine. Never try to wash a dirty filter on the machine.
2. Remove the filter from the air cleaner case.
3. Wash the filter element in a non-flammable or high flash-point solvent to help break down the old filter oil.
4. Do not twist the air filter element when squeezing it, if damaged, replace it.
5. Fill a bucket with one gallon or more of hot soapy water with strong detergent submerge filter into bucket of hot water, and let soak for 10 – 15 minutes.
6. After filter has soaked thoroughly, clean the filter out by hand, be mindful not to tear or rip the filter.
7. It must be rinsed very thoroughly, filter should be back to their original new color.
8. After rinsed, dry in a none dust free places. Make sure the filter is in a completely ventilated area for a minimum of 24 hours or more, until is dry.
9. Apply all-purpose oil to the air filter and reinstall it.

Never operate the engine with the air filter removed. This will allow unfiltered air to enter, causing rapid engine wear and possible engine, carburetor jetting damage.

Maintenance

Carburetor & Drive Chain

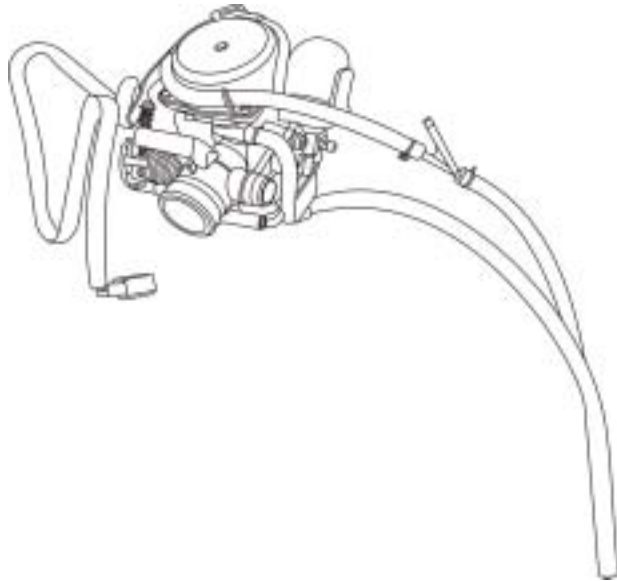

Carburetor adjustment

Keep this part free of dirt and particles. If they enter the engine it may cause severe damage of engine.

The carburetor is a vital part of the engine and requires very sophisticated adjustment. Most adjusting should be left to a authorized dealer who has the professional knowledge and experience to do so.

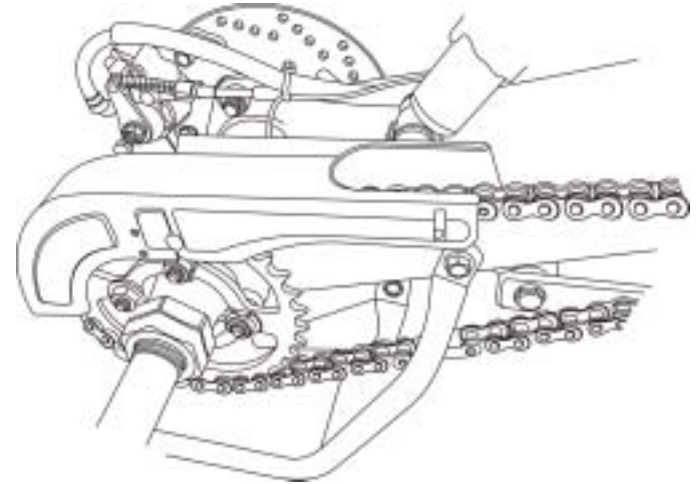

Drive Chain

The drive chain will wear with use and requires periodic adjustment. Remove the chain guard to check the chain tension. The amount of slack should be 10 – 20mm, the chain slack can be adjusted by loosening the lock nuts and removing the chain tensioned plate.

Don't forget to tighten the lock nuts well. Lubricating the chain is sometimes needed. The SAE 80 or 90 gear oil is recommended.

Check for:

Rusted Links / damaged rollers / Twisted or binding Links.

Parts found defective must be replaced.

Maintenance

Disc Brakes

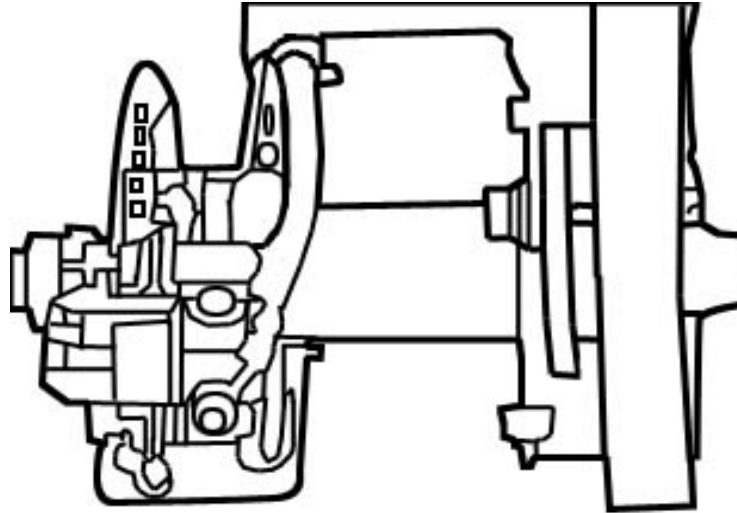

Disc Brakes

150cc Disc Brakes

Check the brake cable for rust or signs of wear that could cause sticking or failure.

Lubricate the brake cable with a available cable lubricant to prevent premature wear or corrosion. Make sure the brake arm, spring, rod and fasteners are in good condition.

Maintenance

Throttle Cable & Battery

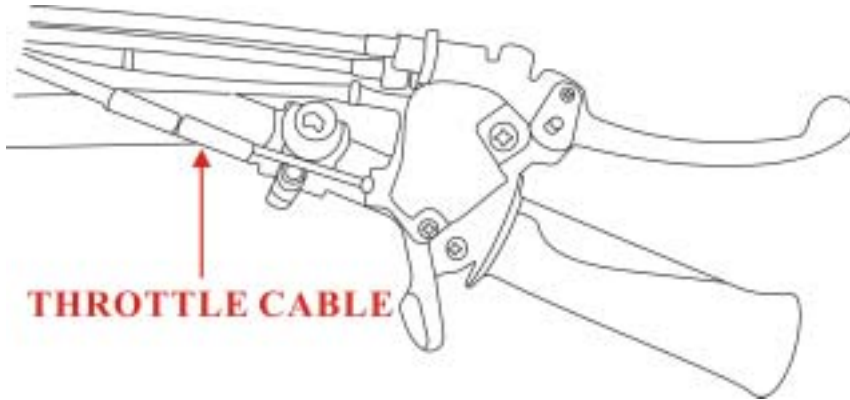

Throttle Cable

Inspect the throttle cable's condition and operation. Replace the cable if it has become worn or kinked.

Keep cable smooth with lubricant to prevent premature wear or corrosion. Adjustments can be made with the adjuster beside the throttle lever.

Loosen the lock nut and turn the adjuster, maintain free play of 5 – 10mm.

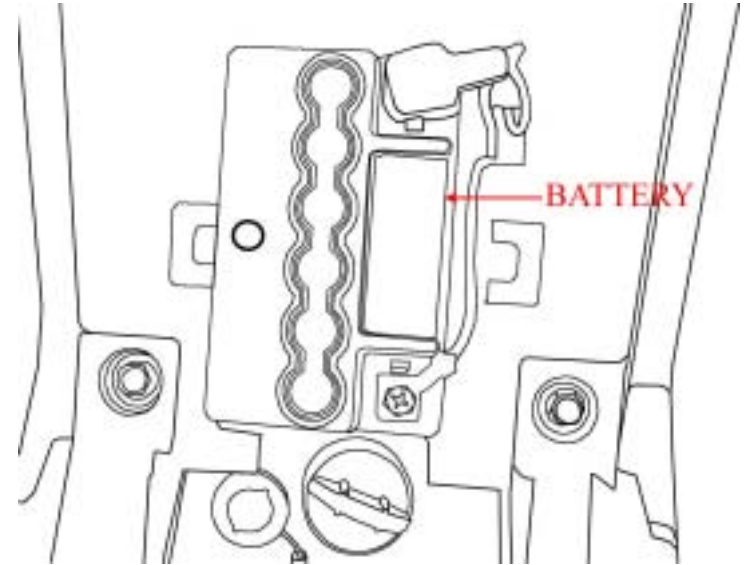

Battery

When reinstalling the battery, be sure to connect the cable to the positive (+) lead and the black cable to negative (-) lead.

Replace the battery immediately when it loses power and does not hold a charge.

On normal service, the battery should be replaced every three years.

Maintenance

Tire Thread



FRONT



REAR

Tire Thread:

- Replace tire when groove becomes less than 3 mm (0.12 in), or has side wall cracks or cuts.
- Worn tires can blow and cause loss of control.
- Tire depth limit: 3mm
- Never apply grease, oil or gasoline to the tire bead; it will diminish the tire.

Wiring Diagram

A7A CIRCUIT DIAGRAM

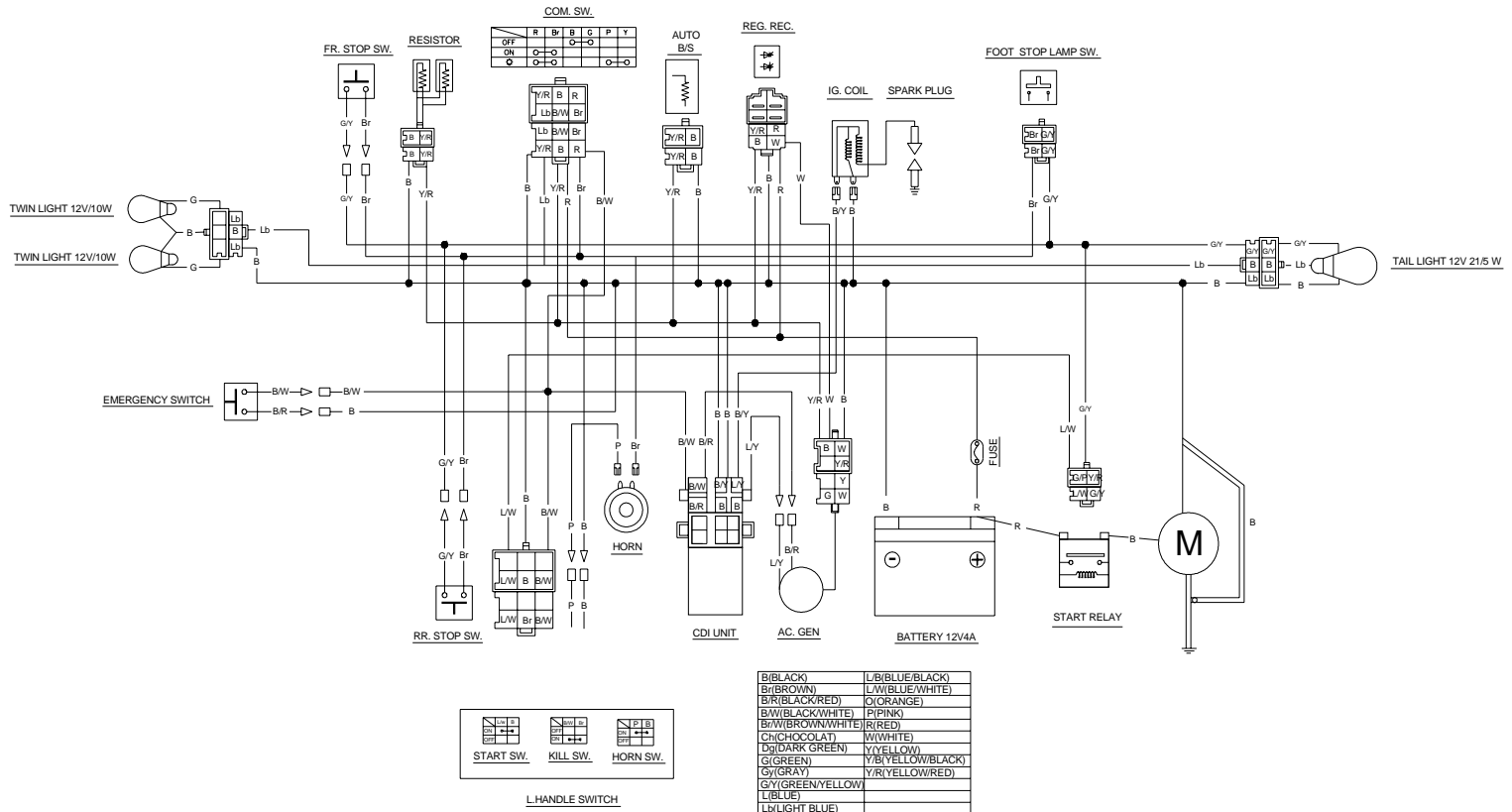

Maintenance Schedule:

The maintenance intervals in table below are based on average riding conditions. Riding in unusually dusty areas requires more frequent servicing.

Parts:	Initial Service (First week)	Regular Service (Every 30 operating days)	(Every) 6 Month	Every Year
Fuel Line			I + D	I + D
Throttle Operation	I	I		
Air Filter		I	I	I
Spark Plug		I + D	I + D	I + D
Carburetor / Idle Speed Adjustment		I + D	I + D	I + D
Crankcase Breather System			I	I
Drive Chain	I	I		
Brake Shoe Wear		I + D	I + D	I + D
Brake System	I + D	I + D	I + D	I + D
Nut, Bolt, Fastener	I	I		
Wheel	I	I	I	I
Steering System		I	I	I
Battery				3 months
C.V.T Air Filter		C		

Note: (**I**): Inspect, check for any leakage or damage, clean, adjust, lubricate or replaced if necessary (**C**): Clean / (**L**): Lubricate

(**D**): By a Dealer / (**R**): Replace

Maintenance Schedule:

Note: Before lubricating each part, clean off any rusty spots and wipe off any grease, oil, dirt or stain.

Parts:	Initial Service (First week)	Regular Service (Every 30 operating days)	6 Month	Every Year
Valves		I + D	I + D	I + D
Exhaust System		I + D	I + D	I + D
Spark Arrester			C	C
Engine Oil		R	R	R
Engine Oil Filter Element			C or R	C or R
Engine Oil Strainer		C	C	C
Clutch		I + D	I + D	I + D
Wheel bearings		I or R	I or R	I or R
Upper & Lower Arm Pivot & Steering Shaft			I + D	I + D
Rear Pivot			I + D	I + D
Fittings & Fasteners		I + D	I + D	I + D
Front & Rear Suspension			I	I
Chassis bolts and nuts		I + D	I + D	I + D
Lights & Switches	I + D	I + D	I + D	I + D

Note: (I): Inspect, check for any leakage or damage, clean, adjust, lubricate or replaced if necessary (C): Clean / (L): Lubricate

(D): By a Dealer / (R): Replace