

UNISON



DESERT CAT 70/90



**California Proposition 65 Warning:** The engine exhaust from this product contains chemicals known to the State of California to cause cancer, birth defects or other reproductive harm.

To protect the environment, do not unlawfully dispose of used motor oil and tires.

**A few words about safety notations, please pay attention and follow signs in your manual booklet:**



**WARNING**

Failure to follow these instructions could result in serious injury or death.



**CAUTION**

Special precautions that must be taken to avoid damage to your ATV.



This symbol indicates please pay **ATTENTION!** Read all the information clearly!

## All Terrain Vehicle (ATV)

Welcome to the growing family of **Unison** owners. This vehicle is delivered to you with confidence and the reliability that has made **Unison** stand out in these fields.

This vehicle is designed and manufactured for **OFF-ROAD** use only; please check your local riding laws and regulations before operating this machine.

Read this manual together with your children. It is important that you take the time to get acquainted with how your ATV works. The user manual provides detailed **safety instructions, operation** and **maintenance** procedures.

An ATV is not a toy and can be hazardous to operate without proper instructions. We highly recommend that you take a training course from a certified instructor.

**Please follow the age recommendation:**

**ATV Size / Minimum Age**

50cc: 6 years and older

90cc: 12 years and older

Over 90cc: 16 years and older

**Please pay close attention to the following labels:**



**ALWAYS USE APPROVED  
HELMET AND  
PROTECTIVE GEAR**



**NEVER USE ON PUBLIC  
ROADS**



**NEVER CARRY  
PASSENGERS**



**NEVER USE WITH  
DRUGS OR  
ALCOHOL**

Congratulations on choosing **Unison** all terrain vehicle (ATV). Happy riding!!!

## Specifications- 70cc

Engine Type:	4 Stroke Horizontal	Suspension Rear:	Single Damper
Max. Power:	5.0 ps / 8000 rpm	Brake Front & Back:	Drum & Drum / Disc
Cylinder No#	1	Front & Rear Tire:	19 x 7-8 / 18 x 9.5-8
Bore Stroke:	47 x 40 mm	Transmission:	Automatic (C.V.T.)
Displacement:	69.3 cc	Fuel:	Unleaded Gasoline
Max. Torque:	4.5 N-m / 6000 rpm	Overall Dimension:	58.3" x 36.6" x 37.2" (1480mm x 930mm x 945mm)
Carburetor:	KEIHIN – KT	Wheelbase:	38.6" / 1030 mm
Starting:	Electric & Kicker	Seat Height:	28" / 711 mm
Lubricant:	Separated	Ground Clearance:	4.1" / 190 mm
Lubricant Capacity:	1 Liter	Dry Weight:	135 kg
Suspension Front:	Single A-Arm	Max. Load:	185 kg

## Specifications- 90cc

Engine Type:	4 Stroke Horizontal	Suspension Rear:	Single Damper
Max. Power:	5.7 ps / 8000 rpm	Brake Front & Back:	Drum & Drum / Disc
Cylinder No#	1	Front & Rear Tire:	19 x 7-8 / 18 x 9.5-8
Bore Stroke:	48 x 49.5 mm	Transmission:	Automatic (C.V.T.)
Displacement:	89.6 cc	Fuel:	Unleaded Gasoline
Max. Torque:	6.3 N-m / 6000 rpm	Overall Dimension:	58.3" x 36.6" x 37.2" (1480mm x 930mm x 945mm)
Carburetor:	KEIHIN – KT	Wheelbase:	38.6" / 1030 mm
Starting:	Electric & Kicker	Seat Height:	28" / 711 mm
Lubricant:	Separated	Ground Clearance:	4.1" / 190 mm
Lubricant Capacity:	1 Liter	Dry Weight:	135 kg
Suspension Front:	Single A-Arm	Max. Load:	185 kg

## Understand your ATV and specifications

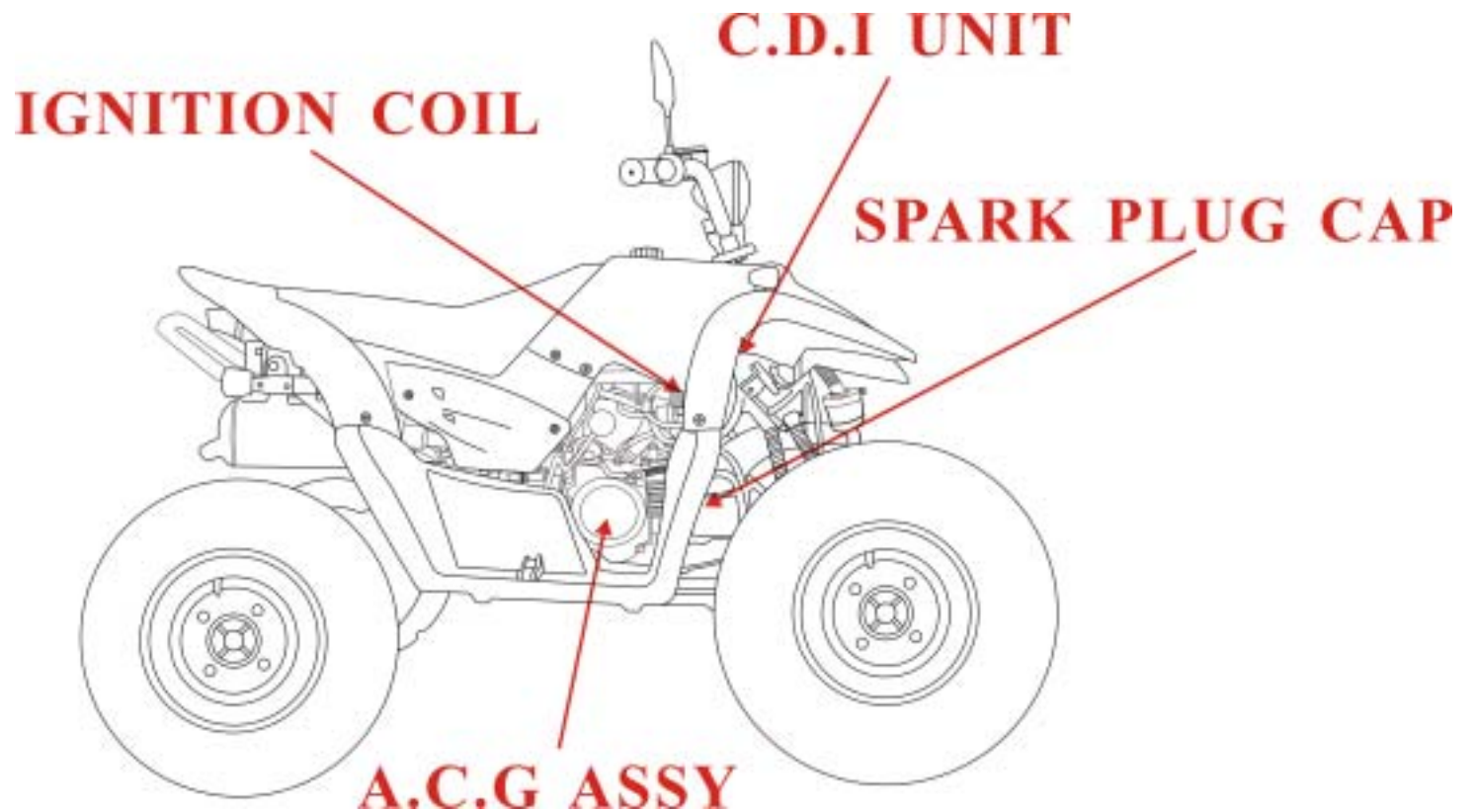

## ATV Parts locations and specifications

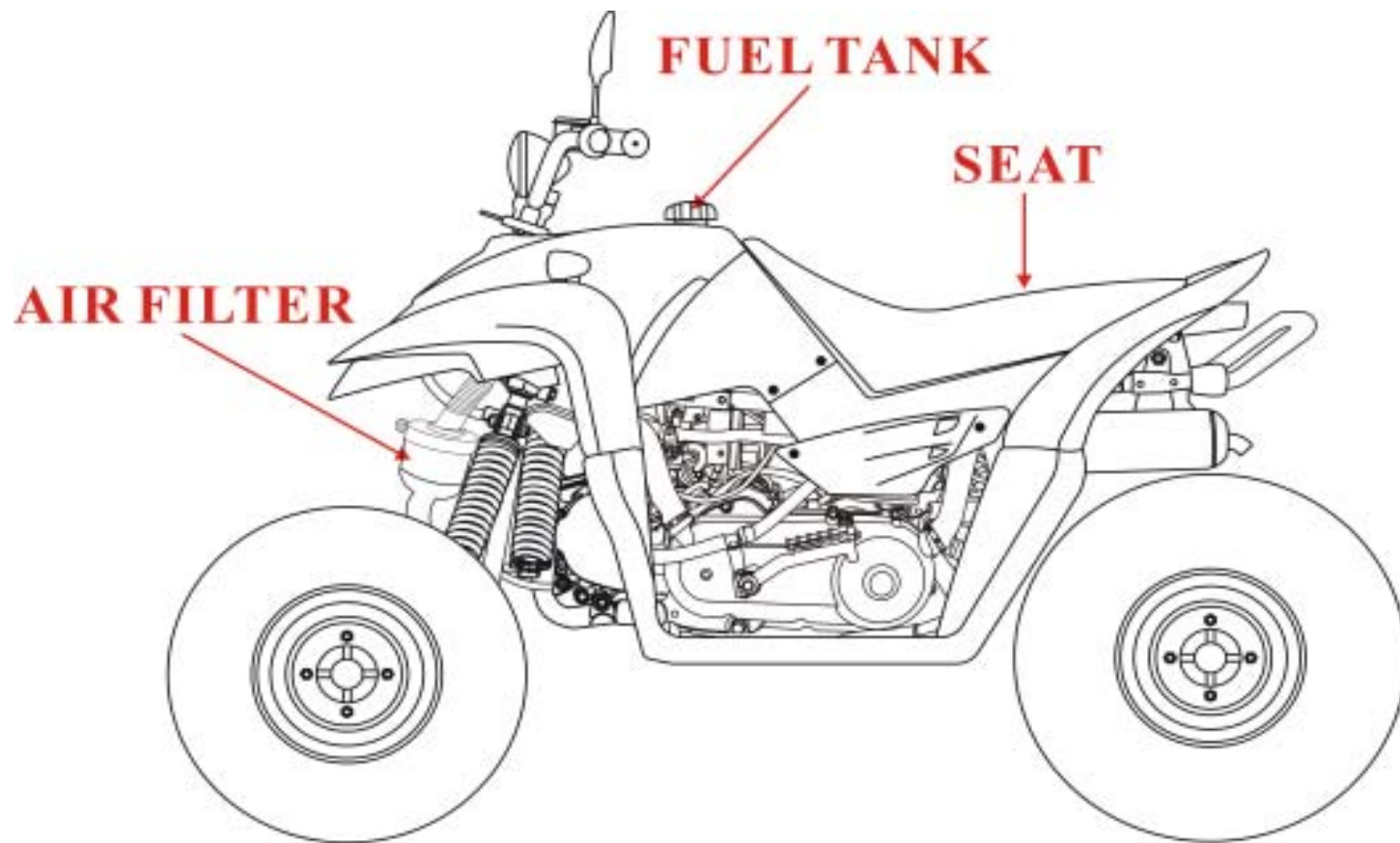

## Are You Ready?



### Important Information



**Before you ride your ATV, we urge you to read and do the followings:**

- Always follow the age recommendation for the ATV.
- Do not allow your child to ride without adult supervision.
- This vehicle is not designed for carrying a passenger. Carrying passengers can cause loss of control resulting in severe injury or death. This vehicle is properly balanced to carry only the operator.
- Never operate without wearing an approved motorcycle helmet that fits properly. We urge you to wear eye goggles, face shield, gloves, boots, long-sleeved shirt or jacket and long pants.
- Never operate this vehicle while under the influence of drugs or alcohol.
- Never operate an ATV on any public street, road, or highway. Try to avoid riding on paved surfaces, including sidewalks, driveways, and parking lots.
- Never operate at speeds faster than your skill, or attempt any stunts. This can result in severe injury.
- Never modify an ATV through improper installation or use of accessories.
- Always use the size and type of tires specified in this manual. Always maintain proper tire pressure as described in this manual.
- Please inspect your ATV each time before use, and make sure it is in safe operating condition.
- Always follow the maintenance procedures.
- Read the warranty thoroughly so you understand the coverage that protects your new ATV and you aware of your rights and responsibilities. After you have read the warranty information please fill out and mail in the warranty registration card provided on page 43 of this manual.
- Always turn off the engine when refueling.
- Do not refuel when the engine is hot or running. Do not spill gasoline on the engine or the exhaust pipe, muffler.
- Never refuel while smoking, and do not use a cellular phone while riding you ATV.

An ATV handles differently from other vehicles, including motorcycles and cars. If you fail to take proper precautions a collision or rollover can occur quickly, even during routine maneuvers such as turning and driving on hills and over obstacles.

## Are You Ready?



### Important Information



- If you have any questions, or if you ever need special service or repairs, remember that your **Unison** dealer knows your ATV the best and is dedicated to your complete satisfaction.
- Never remove any labels from your ATV. If a label becomes difficult to read or comes off, a replacement label is available from your dealer.
- Never run the engine in enclosed areas, the exhaust contains poisonous carbon monoxide.
- Do not touch any part of the engine, muffler or exhaust system while the ATV is still hot.
- Never attempt to operate over large obstacles, such as large rocks or fallen trees. Always check for obstacles before operating in a new area.
- Never operate an ATV in fast flowing water or in water deeper than recommended in this manual. Remember that wet brakes may reduce stopping ability, test your brakes after leaving water. If necessary, apply them several times to let friction dry out the linings.
- When transporting the machine in another vehicle, be sure it is kept upright and that the fuel cock is in the “OFF” position. Otherwise, fuel may leak out of the carburetor or fuel tank.
- Always be careful when skidding or sliding. Learn to safely control skidding or sliding by practicing at low speeds and on level smooth terrain. On extremely slippery surfaces such as ice, go slowly and be very cautious in order to reduce the chance of skidding or sliding out of control.
- ATV handles differently from other vehicles, including motorcycles and cars. A collision or rollover can happen quickly. Even routine maneuvers such as: turning, driving up or down hills, and over obstacles can result in serious injury or death if you fail to take the proper precautions. Be cautious when riding and check your ATV each time before taking off. Always have an emergency first aid kit and tools with you on your ride.

## Are You Ready?

---

### Protective Apparel

- Never operate an ATV without wearing an approved motorcycle helmet that fits properly. You should also wear eye goggles, a face shield, a chest protector, gloves, boots, a long-sleeved shirt or jacket and long pants.



Your helmet is the most important piece of protective gear and can help prevent a serious head injury. Your helmet should fit snugly and fasten securely. Select a helmet that meets or exceeds your state's safety standards. Full face helmets will help protect your face as well as your head.



Open face helmets are lighter and may be cooler, but should be used with eye and mouth protection.



Padded gloves can help keep your hands from getting sore, cold or bruised.



Over-the-ankle boots with low heels can prevent your feet from slipping off the footrest and protect your feet, ankles and lower legs.

## Is Your ATV Ready?

---



**Always inspect your ATV before you ride. Please follow this checklist, it will decrease the possibility of an accident or equipment damage.**

1. Fuel: Check the level, fill with fuel if needed.
2. Engine Oil: Check oil level, fill with oil if needed.
3. Wheels and Tires: Check the tires for wear and damage and also their pressure levels.
4. Switches: Check to make sure they are working properly.
5. Fittings and fasteners: Check for loose fittings and fasteners.
6. Brakes: Check operation of cable or fluid level on front and rear brakes.
7. Parking Brakes: Check for smooth condition and operation.
8. Drive Chain: Check the tension of the chain, make sure there are no damaged or rusted links, and check the sprockets condition.
9. Always warm up the engine for at least 5 minutes before take off, never accelerate hard with a cold engine, it will damage the engine life.
10. **Apply chain lubricant to lubricate the drive chain.**

## **Break-In your ATV**

---

Make sure all fluids have been filled (coolant, trans oil. etc.) before starting a freshly rebuilt or new engine. It is strongly recommended that you make sure the carburetor has been thoroughly cleaned, fuel tank has been flushed clean, fresh fuel/oil mixture has been used, air box has been cleaned, and a new or freshly serviced air filter has been installed. Once the above steps have been completed, start your engine and follow the break-in procedure.

### **Break-In your ATV**

During the first two weeks of riding operate your new vehicle cautiously. Don't run it very fast and don't approach the maximum rpm. Also check the levels of all lubricants constantly.



Following these guidelines will greatly enhance the long-term power and life of the engine.

To get maximum engine life, always warm up the engine for at least 5 minutes before take off, never accelerate hard with a cold engine, it will damage your engines life.

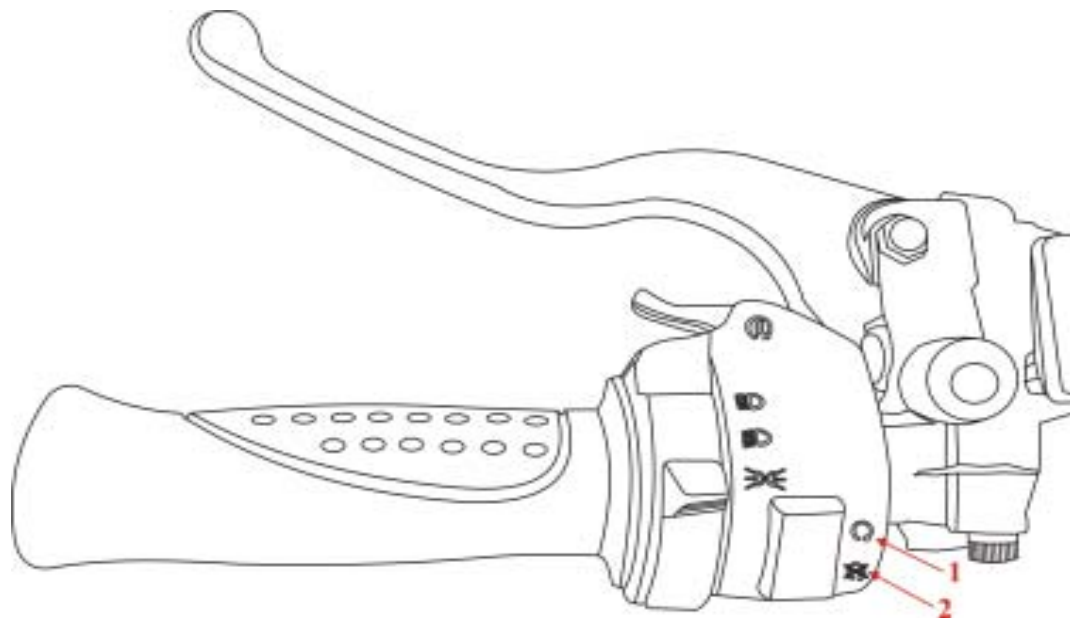
## Engine On / Stop Switches



### 50cc/70cc/90cc/110cc Engine Stop Switch

The engine stop switch is on the left handle-bar. When the switch is in the “” position, the engine is OFF. When the switch is in the “” position, the engine will be ON. This switch also can be used as a safety or emergency switch.

1. On
2. Off

## Engine On / Stop Switches

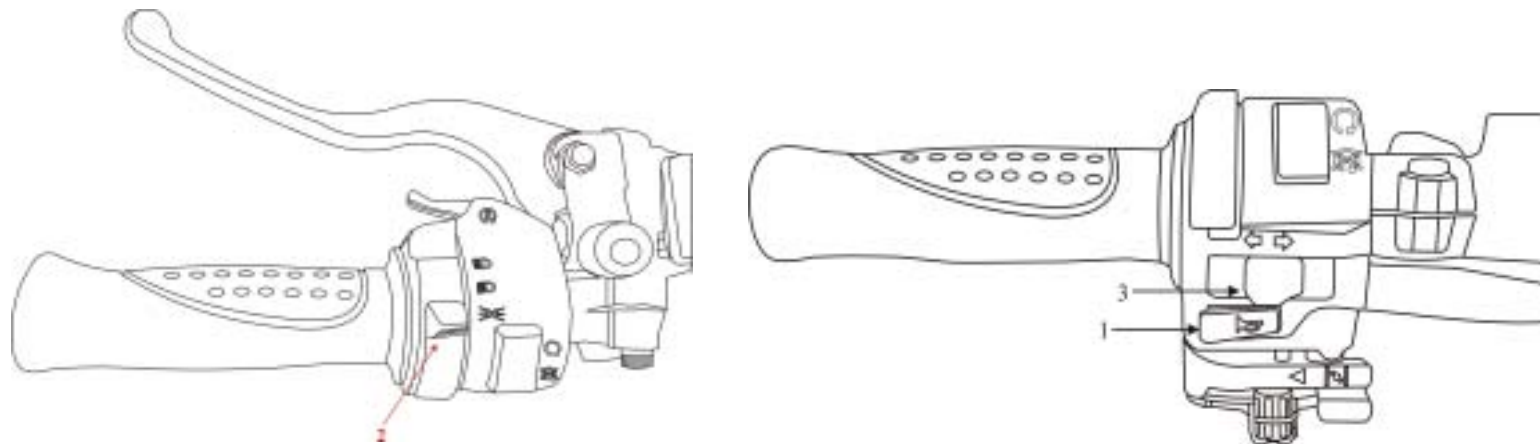

### 1.Horn inspection:

Turn main switch to “” and press down horn switch button to check if the horn sounds.

### 2.Headlight and taillight inspection:For standard model is without it, it’s for option.

Turn main switch to “”. Operate headlight switch to check if headlight and taillight light. Check the lights if any dirt or damage.

### 3.Turn signal light inspection:

Turn main switch to “”

Operate turn signal switch to make sure if turn signal lights and turn signal indicators blink.

Check turn signal lights if any dirt or damage.

## Starting Procedure

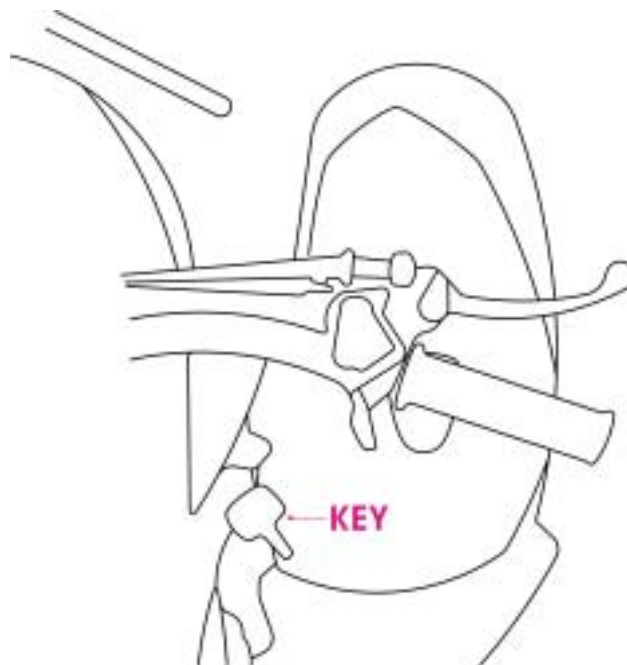

### Starting Procedure

- Park the vehicle on a level surface and lock the parking brake.
- Insert the ignition key into its switch and turn it to the “ON” position.
- Turn the fuel valve to “ON”.
- Move the engine stop switch to “”.
- Push the throttle lever lightly.
- Push the start button on the left handle bar.

## Throttle Lever

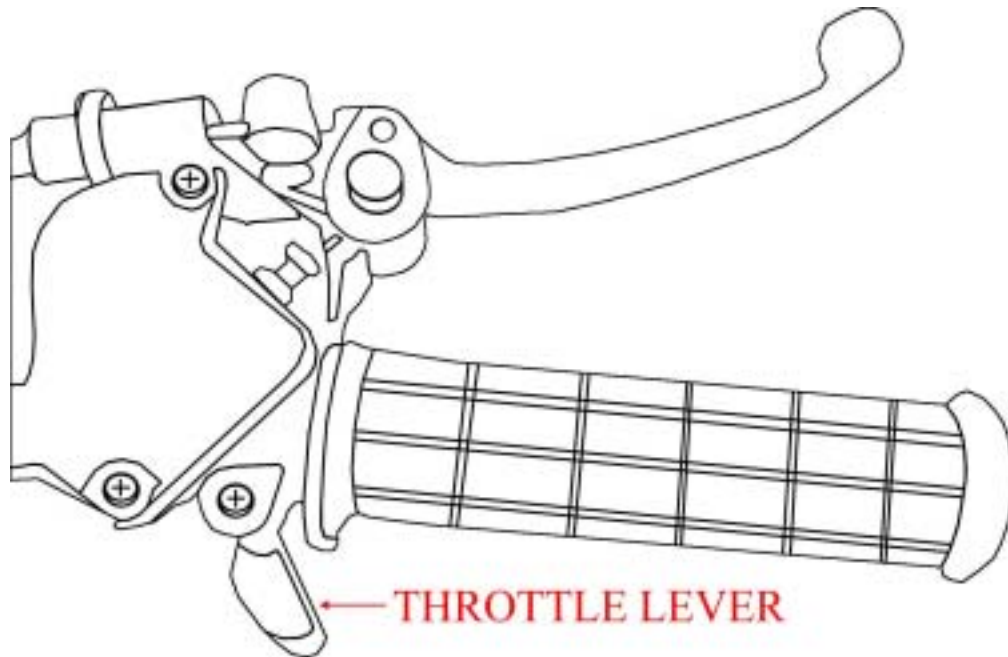

### Throttle Lever

The throttle lever is beside the right handle bar grip and is controlled by your right thumb. To accelerate the vehicle, simply press the lever forward and open the throttle. To decelerate, release the lever and the spring tension will close the throttle automatically.

Before starting the engine, check the throttle to be sure it can operate smoothly. Make sure it returns back to the idle position as soon as the lever is released.

## Front Brake & Rear Brake



### Rear Brake

The rear brake is the lever located on the left handlebar. When braking, squeeze this lever. This brake also has a locking feature that allows it to act as a parking brake. To use the parking brake, pull the left-brake lever back and lock it. Make sure the vehicle is completely stopped before using the parking brake. To release the parking brake, firmly squeeze the left brake lever until the lock release.

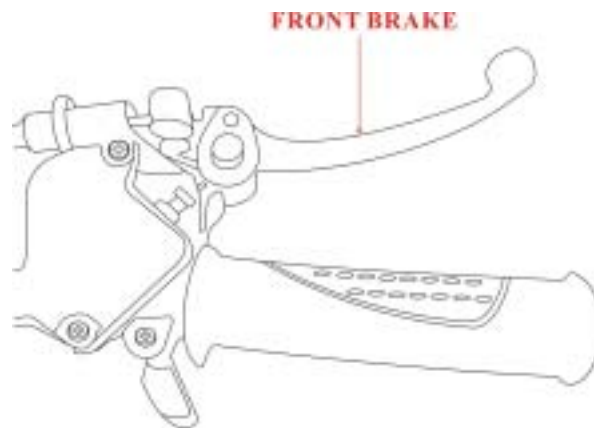

### Front Brake

The front brake lever is located on the right handlebar, pull it towards you to apply the front brake.

Check your brakes at the start of every ride. Do not ride the **ATV** if you find any problem with the brakes. Please contact your local dealer to fix the problem.



## Engine Oil

### Engine Oil

We recommend that engine oil is changed per every 30 operating days or 1000km in the first time. Then check oil once a month, and Please add the engine oil if the oil hasn't reached the MIX mark of the hold.

### The way to check and change the engine oil:

Please follow the direction to check the window of engine oil. It means oil enough if it has located between in MIN and MAX. If it is under MIN, please add engine oil; if it is over MAX, please leak some engine oil out.

### The way to change the engine oil:

Please follow the direction and take off the screw to leak out the oil. To lock the screw back after oil leaked. Take off the bigger screw of oil hole, and to add the engine oil into it.

Engine oil for 4-stroke model: **SAE 40W**

Capacity: **900~1000cc**

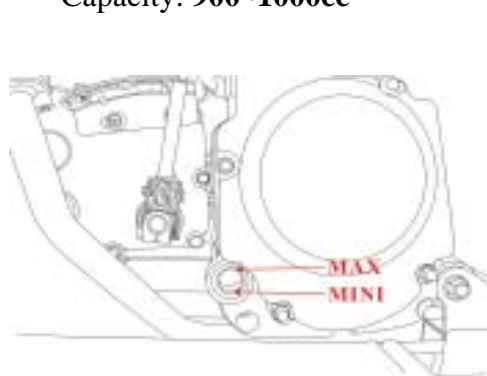

## Gear Oil

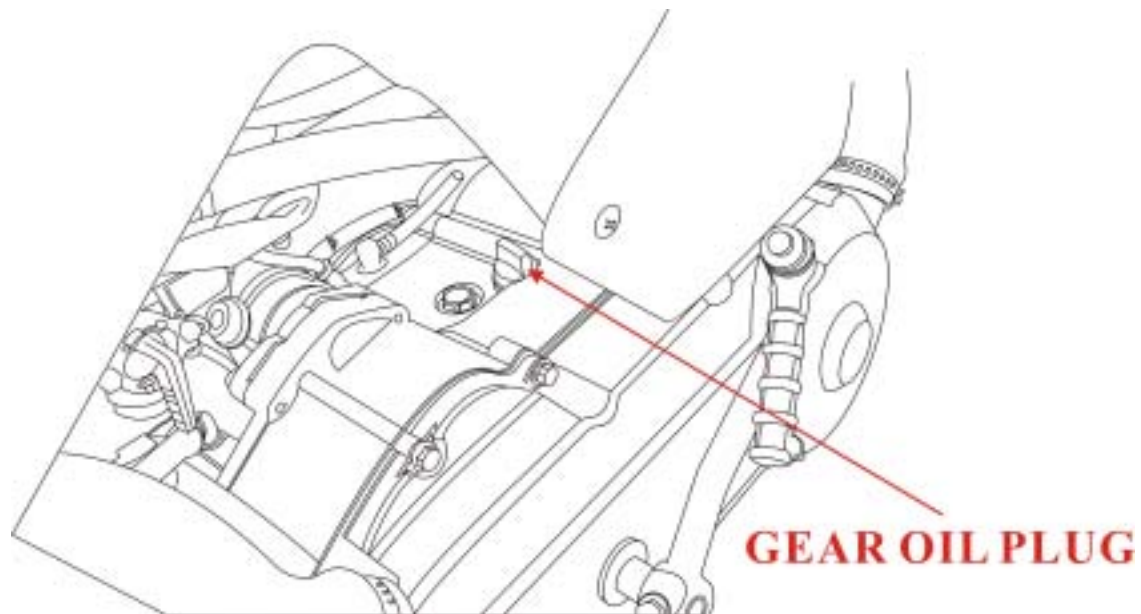

### Gear Oil

- 1 .The oil plug for adding the engine oil.
- 2 .Gear oil : **SEA 90W**  
Capacity : **150cc**

## Fuel Valve & Fuel Tank

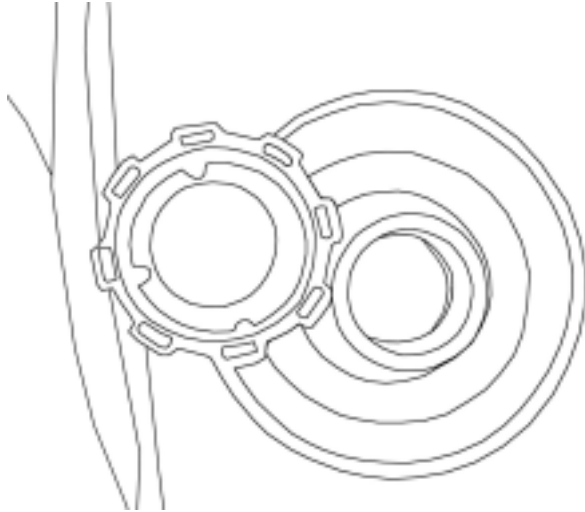

### Fuel Tank

Fuel tank capacity is 5 liters (1.32 gallons) including 0.8 liter (0.21 gallon) in the reserve supply.

Use only unleaded automotive gasoline with an octane level from 87, 89 or 91.

After refueling, be sure to tighten the tank cap firmly.



Be careful not to spill fuel or overfill the fuel tank, it can cause severe injury or fire. Turn off cellular phones and do not smoke when refueling.

If the tank overflows, wipe off any spilled fuel immediately. Make sure the fuel tank cap is closed securely.

## Tires Pressure



If the tire pressure is too high or too low, steering will be affected and tire wear will be increased.

**Operating tire pressure:** You should check the pressure before running the vehicle when the tires are cold.

**•Recommended for 50cc/70cc:**

Max. pressure: 6psi

Min. Pressure: 3psi

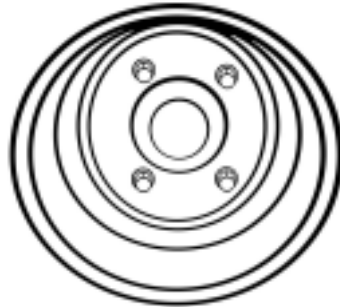

**•Recommended for 90cc/110cc:**

Max. pressure: 8psi

Min. Pressure: 3psi

**NOTE: Do not inflate the tire with more than 10psi of pressure. Seal damage may occur.**

- Never set tire pressure below minimum, it could cause the tire to dislocate from the rim.

**Load Rating:**

- Maximum vehicle load for the **50cc/70cc**: 179 lbs, includes weight of operator, cargo and accessories.
- Maximum vehicle load for the **90cc/110cc**: 190 lbs, includes weight of operator, cargo and accessories.

## Vehicle Identification Number (VIN) & Engine Number

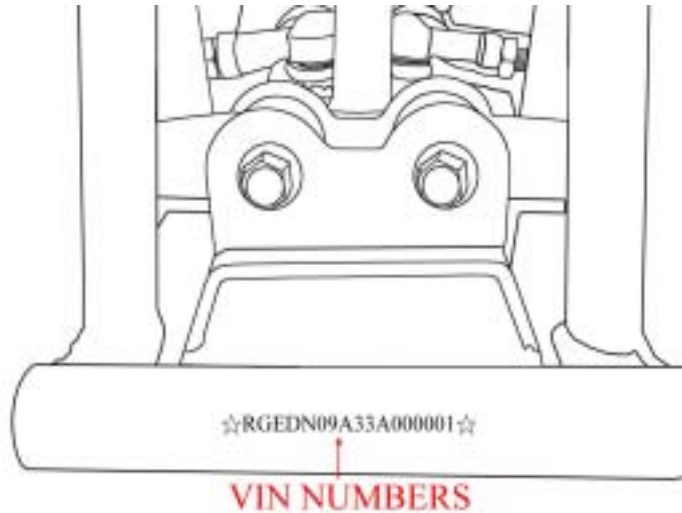

### VIN Numbers

The frame, VIN and engine serial numbers are required when you register your ATV. They may also be required when ordering replacement parts.

Please record the frame and engine serial number for future reference.

Frame No. \_\_\_\_\_

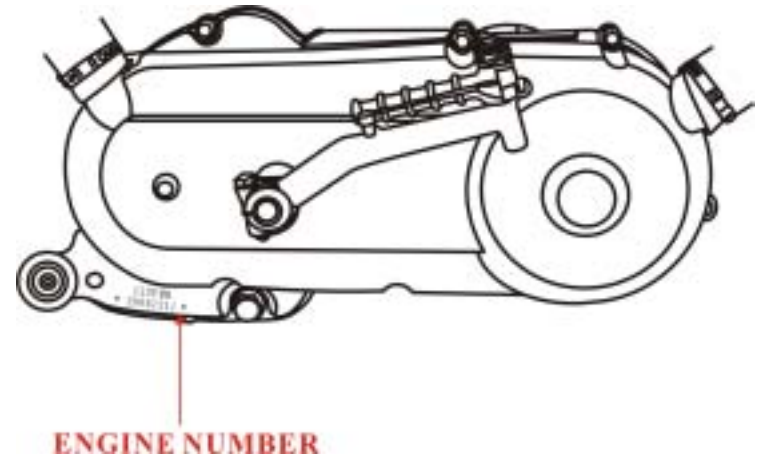

### Engine Number

To find the engine number you will need to remove the left side cover. To determine which side of the ATV is the left, look for the kick start arm or sit on the ATV and it will be on the rider's left.

Engine No. \_\_\_\_\_

## Under the seat

## Posture

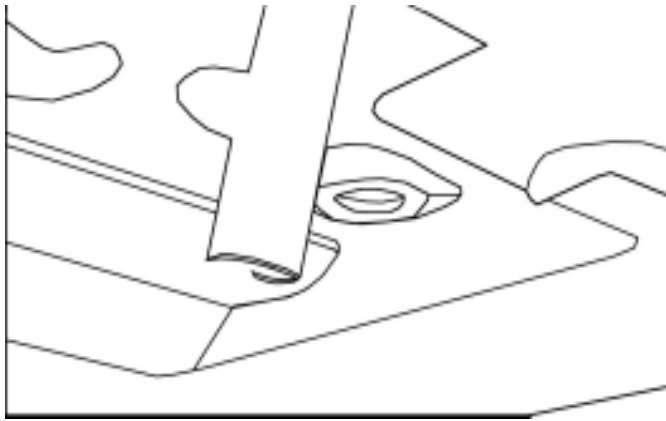

### Remove the seat

Under the **ATV** seat there is a safety knob. Pull forward to remove the seat cover. You will be able to find the battery and tool kit.

- Head and eyes up, looking well ahead.
- Shoulder relaxed, elbows bent slightly out away from your body.
- Keep hand on the handlebars and wrists should always be straight.
- Knees toward the gas tank.
- Feet on the footboards during operation. Otherwise your feet may contact the rear wheels.
- Always keep your hands on the handlebars and foot on the footrest at all time.

## Turning

---



The rider must learn to move his weight and control the throttle to allow the rear tires to turn properly. When turning, the wheels on the outside of the turn must travel a wider radius and thus a greater distance than the wheels on inside of the turn. Since the rear wheel axle does not permit a differing rate of wheel rotation, it is enough to merely steer this vehicle into a turn.

To turn properly, steer in the direction of the turn and lean your body to the inside of the turn while supporting your weight on the outer foot. Use the throttle to maintain power throughout the turn. Incorrect turning may cause the front wheels to slide straight ahead. If this should occur, close the throttle and stop. Avoid braking or accelerating until you have regained directional and speed control in order to avoid skids or while traveling on slippery terrain.

## Riding Uphill

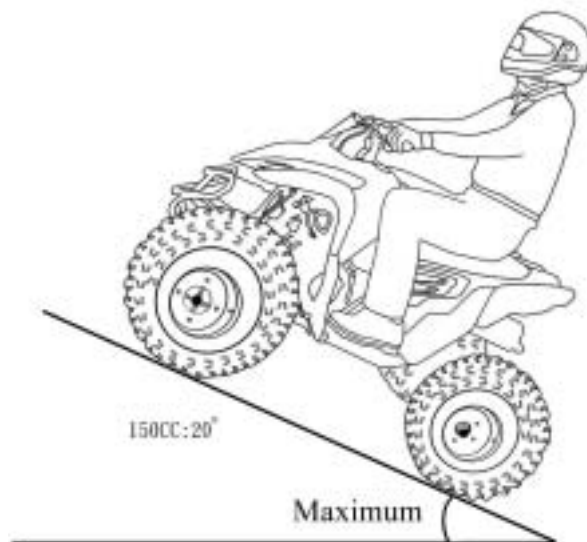

### Uphill

- Practice riding at first on gentle slopes. Try more difficult hills only after developing and being comfortable with your basic skills.
- Avoid excessive steep hills or slopes, this could cause loss of control or the **ATV** to overturn.
- Keep both feet on the footrest at all times. When climbing a hill, shift your body weight forward at all times, proceed at a steady rate of speed and throttle opening.
- Never ride past the limit of your visibility. Slow down or stop. Proceed slowly only when you have a clear view.
- If you are unable to continue uphill, dismount the vehicle on the uphill side, turn the vehicle around and then descend the hill.
- If you cannot complete the hill due to steepness, do not engage the rear brake to stop from rolling backwards. This can easily tip the **ATV** backwards. Engage front brake and dismount the **ATV**. Only remount after turning the **ATV** around.

## Riding Downhill



### Downhill

- To go downhill, shift your body weight back, choose a low gear which will allow the engine compression to do most of the braking for you, improper braking may cause a loss of traction.
- Be cautious when going downhill with loose or slippery surfaces.
- Choose a straight down hill path and avoid obstacles.
- Avoid going down a hill at an angle.
- Use the brake(s) to slow you down as you going downhill and always use a low gear.
- Never go down a hill at high speeds. Always maintain control of speed.

## Crossing A Slope

---



When you go across a slope rather than directly up or down, it's called traversing. Traversing a sloping surface on your **ATV** requires you to properly position your weight to maintain proper balance. Be sure that you have learned the basic riding skills on flat ground before attempting to cross a sloping surface.

- Lean your body uphill direction as you travel across a slope and keep both feet firmly on the footrests.
- When riding on the loose surfaces, you may need to turn your front wheel(s) gently uphill to keep straight line across the hill.
- Make sure not to attempt any sharp turns either up or downhill.
- If your **ATV** does begin to tip over, turn the front wheel(s) downhill direction if there are no obstacles in your path or dismount the **ATV** immediately!
- Avoid hills with excessively slippery or loose surfaces, it could cause loss of control or cause the **ATV** to over turn.

## Crossing Through Shallow Water



The **ATV** can be used to cross slow moving, shallow water of up to maximum of in depth.

Before entering the water, choose your path carefully.

Enter where there is no sharp drop off, and avoid rocks or other obstacles which may be slippery or upset the **ATV**. Drive slowly and carefully.



Remember that wet brakes may have reduced stopping ability. Test your brakes after leaving water until you have regained proper braking ability.

Never operate this **ATV** in fast flowing water or in water deeper than specified in your manual book.

After riding in the water, be sure to drain the trapped water by removing the check hose at the bottom of the air filter case.

Wash the **ATV** in fresh water if it has been operated in salt water or muddy conditions.

## Maintenance: Spark Plug

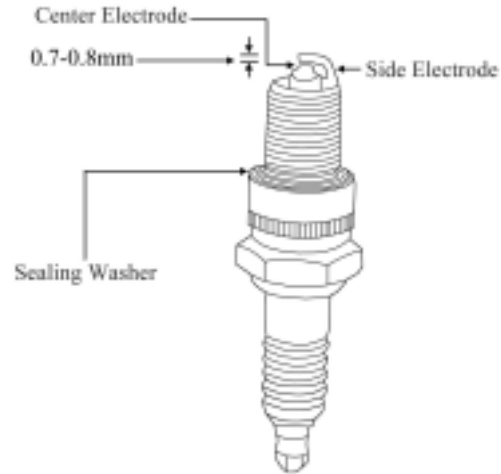

### Spark Plug

Inspect spark plugs every other month for maximum efficiency. Replace the plugs when necessary.

Standard spark plug: **NHSP LD A7T (063)**

1. Disconnect the spark plug cap.
2. Clean up dirt from around the spark plug base.
3. Remove the spark plug.
4. Inspect the plug electrodes for wear. If the electrodes and insulator tip appear unusually fouled or burned, replace the spark plug.
5. The spark plug plug gap is 0.7 – 0.8mm. If adjustment is necessary, bend the side electrode carefully.
6. When installing the spark plug, screw it in finger tight and then tighten with a plug wrench another ½ turn to compress the washer. Do not over tighten.

## Maintenance

### Air Filter



#### Air Filter

The air filter will accumulate dust and must be cleaned periodically. If riding in very dusty area, the filter must be cleaned more frequently.

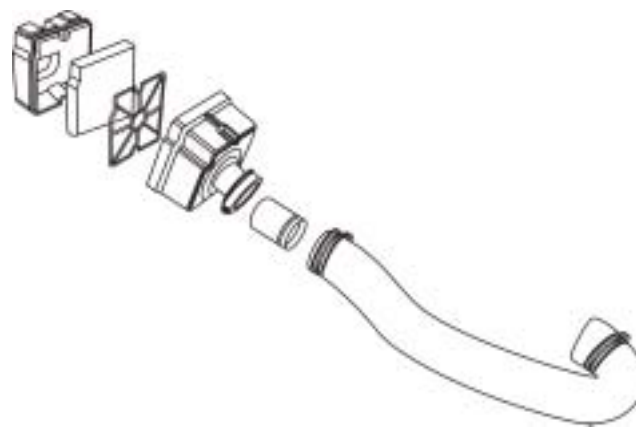

1. Remove dirty air filter from machine. Never try to wash a dirty filter on the machine.
2. Remove the filter from the air cleaner case.
3. Clean the dusty air gun.
4. Do not twist the air filter element when squeezing it, if damaged, replace it.
5. Under normal riding the sponge filter must t be cleaned per every 3 months by air gun if riding the ATV frequently or in dusty environment, and then sponge filter must to be cleaned each month by air gun.
6. The sponge in side the filter must be changed every 6 months.
7. Screen and sponge inside filter must be changed every 1 year.

Never operate the engine with the air filter removed. This will allow unfiltered air to enter, causing rapid engine wear and possible engine, carburetor jetting damage.



#### Air Filter

The air filter will accumulate dust and must be cleaned periodically. If riding in very dusty area, the filter must be cleaned more frequently.

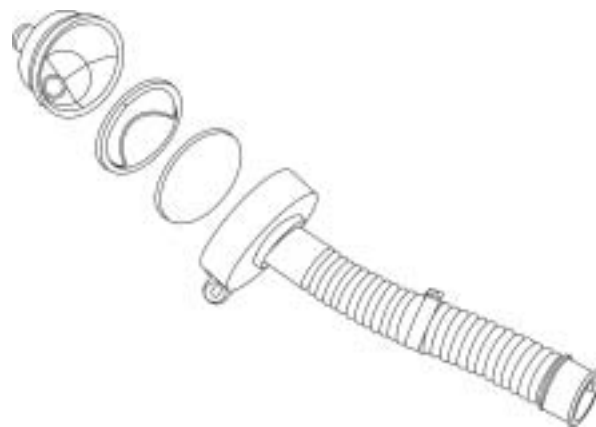

1. Remove dirty air filter from machine. Never try to wash a dirty filter on the machine.
2. Remove the filter from the air cleaner case.
3. Clean the dusty air gun.
4. Do not twist the air filter element when squeezing it, if damaged, replace it.
5. Under normal riding the sponge filter must t be cleaned per every 3 months by air gun if riding the ATV frequently or in dusty environment, and then sponge filter must to be cleaned each month by air gun.
6. The sponge in side the filter must be changed every 6 months.
7. Screen and sponge inside filter must be changed every 1 year.

Never operate the engine with the air filter removed. This will allow unfiltered air to enter, causing rapid engine wear and possible engine, carburetor jetting damage.

## Maintenance

### Carburetor & Drive Chain

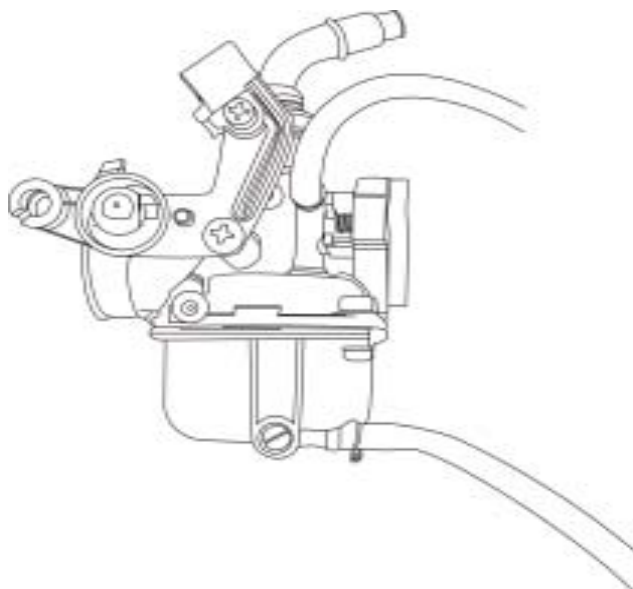

#### Carburetor adjustment

Keep this part free of dirt and particles. If they enter the engine it may cause severe damage of engine.

The carburetor is a vital part of the engine and requires very sophisticated adjustment. Most adjusting should be left to a authorized dealer who has the professional knowledge and experience to do so.

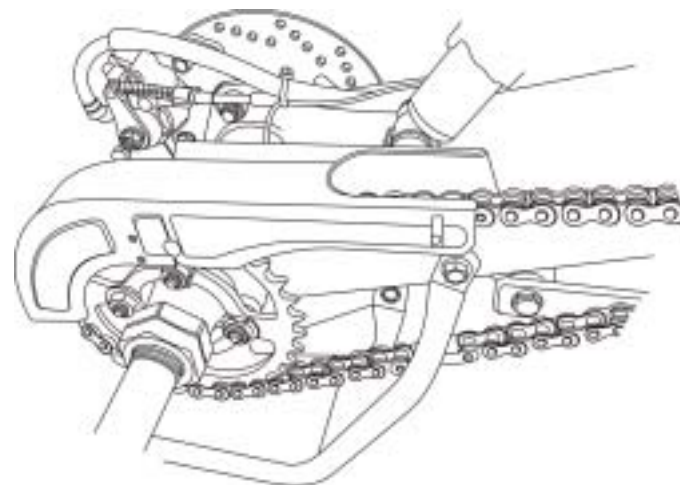

#### Drive Chain

The drive chain will wear with use and requires periodic adjustment. Remove the chain guard to check the chain tension. The amount of slack should be 10 – 20mm, the chain slack can be adjusted by loosening the lock nuts and removing the chain tensioned plate.

Don't forget to tighten the lock nuts well. Lubricating the chain is sometimes needed. The SAE 80 or 90 gear oil is recommended.

#### Check for:

Rusted Links / damaged rollers / Twisted or binding Links.

Parts found defective must be replaced.

## Maintenance: Drum/Disc Brakes

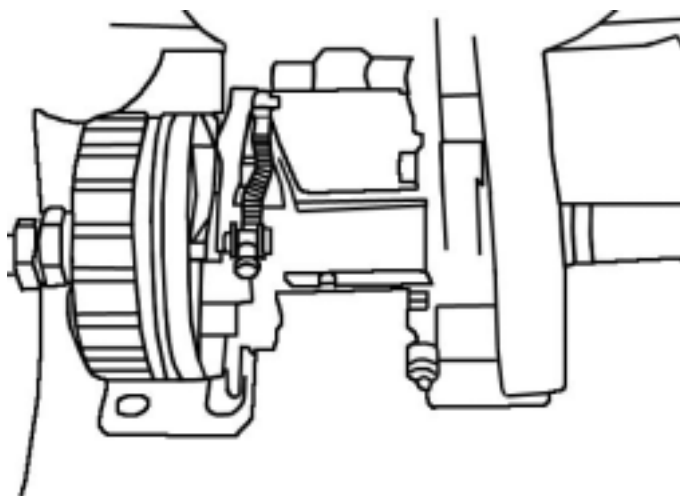

**Drum Brakes**

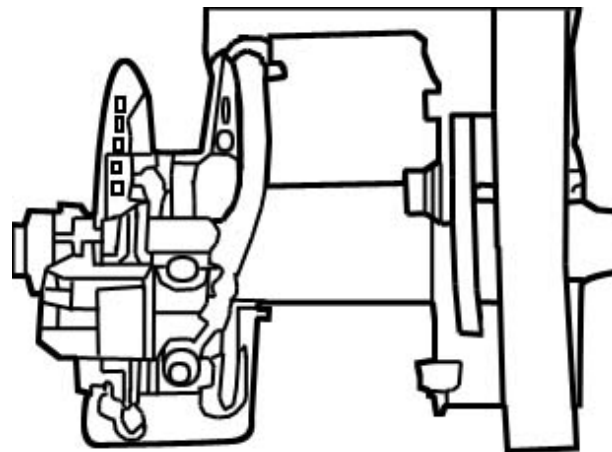

**Disc Brakes**

### **Drum/Disc Brakes**

Check the brake cable for rust or signs of wear that could cause sticking or failure.

Lubricate the brake cable with any available cable lubricant to prevent premature wear or corrosion. Make sure the brake arm, spring, rod and fasteners are in good condition.

## Maintenance: Throttle Cable & Battery

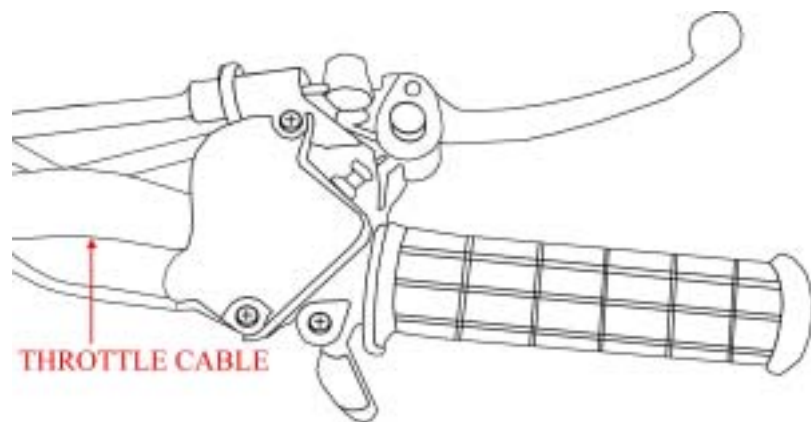

### Throttle Cable

Inspect the throttle cable's condition and operation. Replace the cable if it has become worn or kinked.

Keep cable smooth with lubricant to prevent premature wear or corrosion. Adjustments can be made with the adjusting screw beside the throttle lever.

Loosen the lock nut and turn the adjuster, maintain free play of 5 – 10mm.

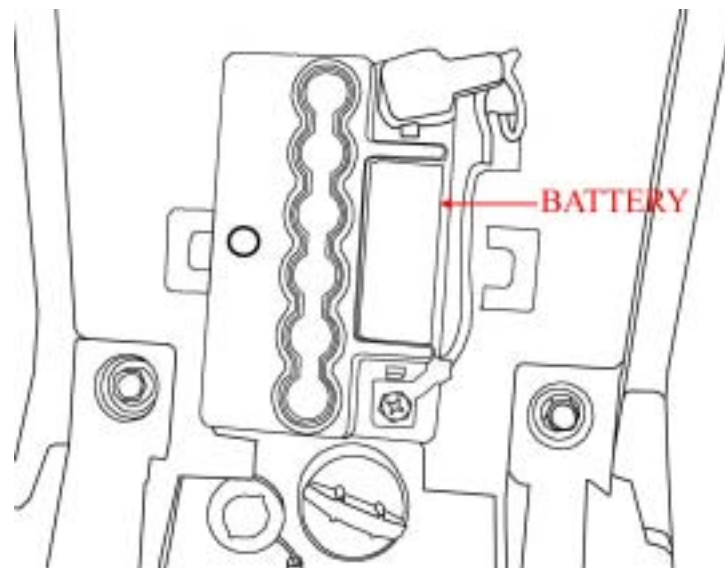

### Battery

When reinstalling the battery, be sure to connect the red cable to the positive (+) lead and the black cable to the negative (-) lead.

Replace the battery immediately when it loses power and does not hold a charge.

Normally the battery should be replaced every three years.

## Maintenance

### Tire Thread

---



#### **Tire Thread:**

- Replace tire when groove becomes less than 3 mm (0.12 in), or has side wall cracks or cuts.
- Worn tires can blow and cause loss of control.
- Tire depth limit: 3mm
- Never apply grease, oil or gasoline to the tire bead; it will diminish the tire.

# Wiring Diagram

## C4A CIRCUIT DIAGRAM

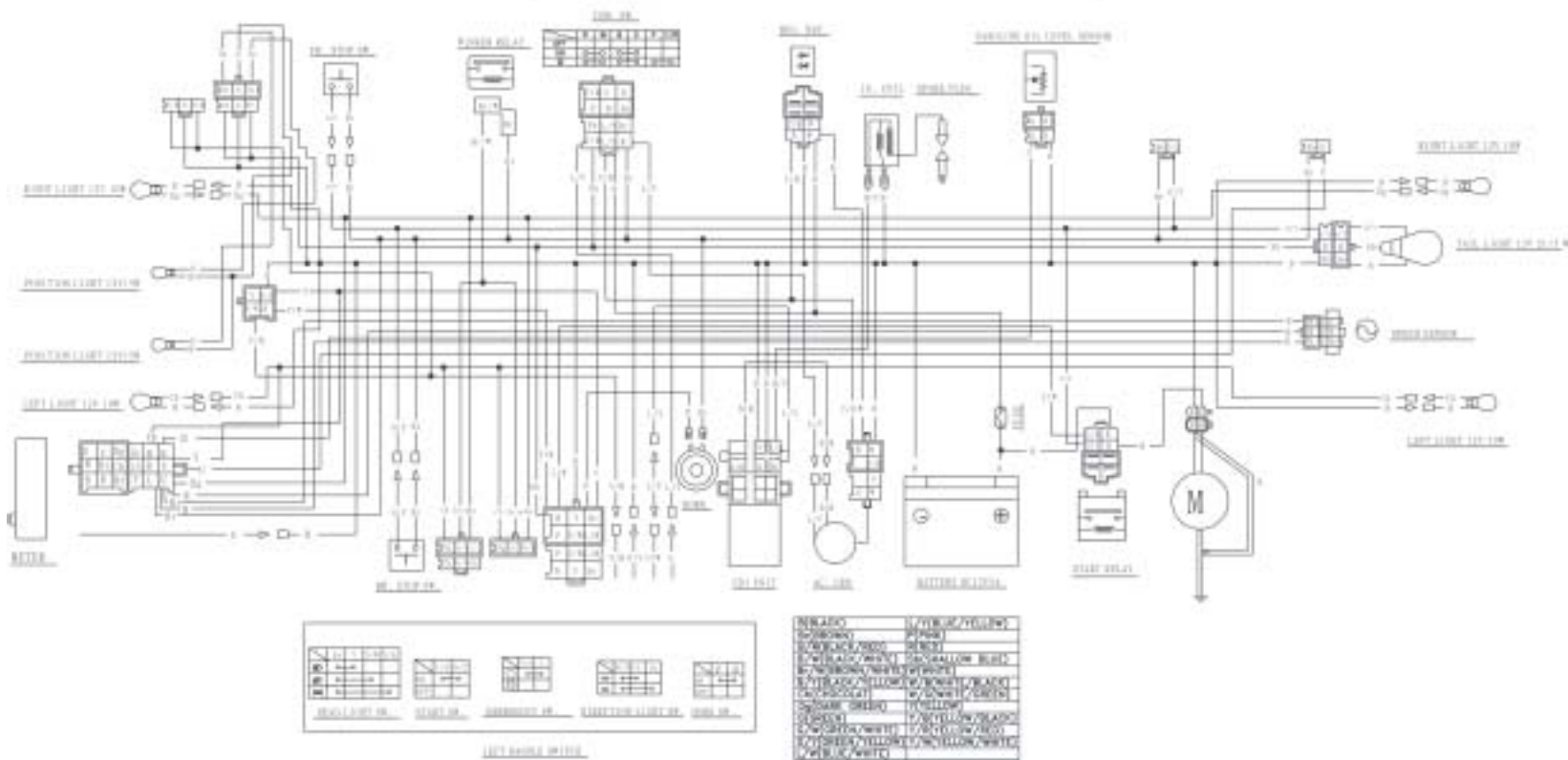

## Maintenance: Keep It Clean

---

### Keep It Clean

To protect your ATV from rust, hose off any mud or dirt before storing; do not let the water sit on the parts for an extended period of time.

Do not use high-pressure water, this can cause damage to engine or drive shaft.

Before cleaning the machine, make sure you block off the exhaust pipe with a plastic bag to prevent water from entering the exhaust system..

If it is necessary to replace any parts always use Unison parts or their equivalent.

## Maintenance Schedule:

The maintenance intervals in table below are based on average riding conditions. Riding in unusually dusty areas requires more frequent servicing.

Parts:	Initial Service (First week)	Regular Service (Every 30 operating days)	(Every) 6 Month	Every Year
Fuel Line			I + D	I + D
Throttle Operation	I	I		
Air Filter		I	I	I
Spark Plug		I + D	I + D	I + D
Carburetor / Idle Speed Adjustment		I + D	I + D	I + D
Crankcase Breather System			I	I
Drive Chain	I	I		
Brake Shoe Wear		I + D	I + D	I + D
Brake System	I + D	I + D	I + D	I + D
Nut, Bolt, Fastener	I	I		
Wheel	I	I	I	I
Steering System		I	I	I
Battery				3 months

**Note:** ( I ): Inspect, check for any leakage or damage, clean, adjust, lubricate or replaced if necessary ( C ): Clean / ( L ): Lubricate  
( D ): By a Dealer / ( R ): Replace

## Maintenance Schedule:

**Note:** Before lubricating each part, clean off any rusty spots and wipe off any grease, oil, dirt or stain.

Parts:	Initial Service (First week)	Regular Service (Every 30 operating days)	6 Month	Every Year
Valves		I + D	I + D	I + D
Exhaust System		I + D	I + D	I + D
Spark Arrester			C	C
Engine Oil	R	R	R	R
Engine Oil Filter Element			C or R	C or R
Engine Oil Strainer		C	C	C
Clutch		I + D	I + D	I + D
Wheel bearings		I or R	I or R	I or R
Arm Pivot & Steering Shaft			I + D	I + D
Rear Pivot			I + D	I + D
Fittings & Fasteners		I + D	I + D	I + D
Front & Rear Suspension			I	I
Chassis bolts and nuts		I + D	I + D	I + D
Lights & Switches	I + D	I + D	I + D	I + D

**Note:** ( I ): Inspect, check for any leakage or damage, clean, adjust, lubricate or replaced if necessary ( C ): Clean / ( L ): Lubricate  
( D ): By a Dealer / ( R ): Replace



**UNISON MOTORS**

---

[WWW.UNISONMOTORS.COM](http://WWW.UNISONMOTORS.COM) • TEL: 626.455.0578 • FAX: 626.387.5452