



UNISON

ILLUSTRATED PARTS LIST

RAGE 250 & MOBILITY 250

MODELS 2004 AND UP (VER.A)

250cc SERIES

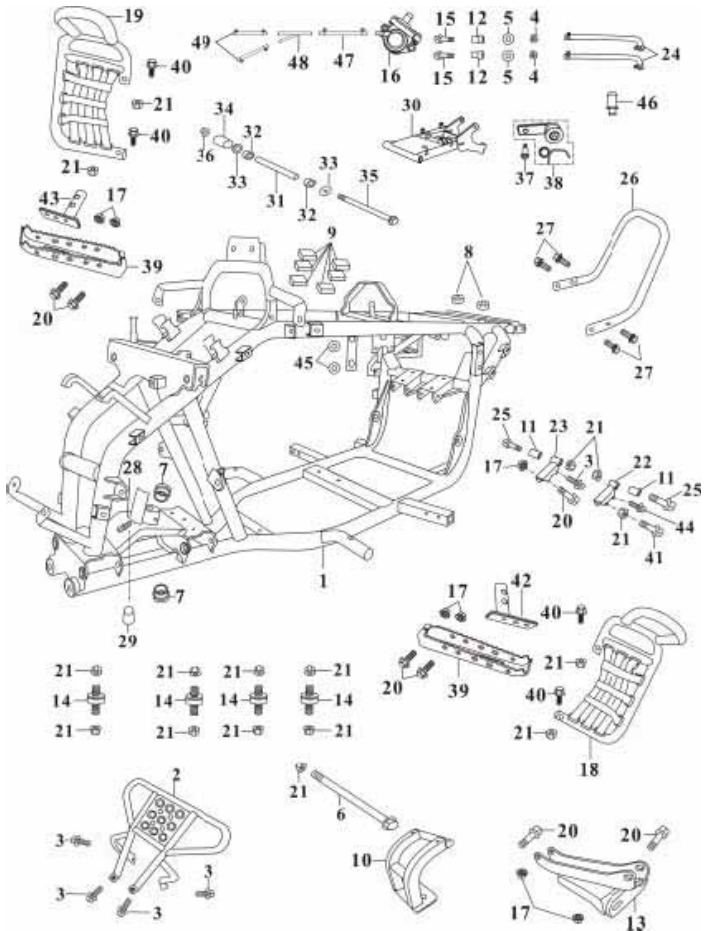
F1**FRAME BODY****R250CC**

ITEM	UNISON NO.	PARTS NO.	DESCRIPTION	QTY
1	14032501	C2A-51110-00-00	FRAME COMP.	1
2	14032502	C2A-52151-90-00	FRONT FENDER ROD	1
3	14000016	95800-08014-02	FLANGE BOLT 8X14	14
4	15000014	94051-06000-01	FLANGE U NUT 6MM	14
5	09000002	94101-06193-00	PLATE WASHER 6MM	4
6	14052514	95802-10210-01	FR. WHEEL AXLE 10X210	1
7	14021509	A4A-52197-00-00	HOLDER SEAT	2
8	14000024	A1A-52146-00-00	RUBBER	2
9	14000023	A1A-52156-00-00	DAMPER,1	8
10	14032511	A9A-52171-00-10	E/G HANGER BRKT	2
11	14032512	A9A-52173-00-10	BUSH	4
12	14052535	C2D-62823-00-00	COLLAR 17MM	4
13	43002509	SEA-50380-00	DOWN E/G HANGAR BRKT	1
14	14052513	C2A-52173-00-00	RUBBER BUSH	4
15	07000009	96001-06035-02	FLANGE BOLT 6X35	2
16	14052533	C2D-62810-00-00	REED VALVE	1
17	14000020	94051-08000-03	FLANGE NUT 8MM	6
18	14032519	A7A-59550-60-03	NERF BAR ASSY. 1, RED	1
19	14032520	A7A-59560-60-03	NERF BAR ASSY. 2, RED	1
20	14000026	95701-08050-03	FLANGE BOLT 8X50	4



F1

FRAME BODY

R250CC

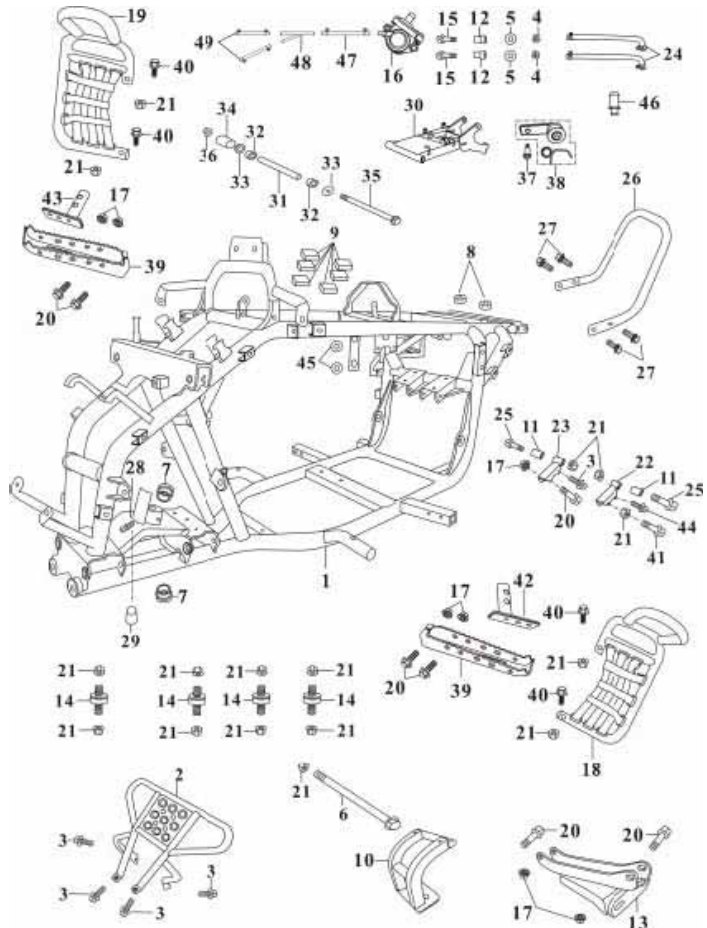

ITEM	UNISON NO.	PARTS NO.	DESCRIPTION	QTY
21	17000001	94061-10000-03	FLANGE U NUT 10MM	11
22	14052519	C2A-52174-00-00	E / G HANGER BRKT	1
23	14032503	C2A-52184-00-00	R.R. E/G STAY,2	1
24	26000023	A3D-62814-00-00	INTAKE AIR DUCT	2
25	14052521	95802-10065-03	FLANGE BOLT 10X65	1
26	14032527	A4A-52155-00-10	REAR ARMRESTS	1
27	14000019	95800-08016-02	FLANGE BOLT 8X16	8
28	25000011	A1A-57367-00-00	GREASE VALVE	6
29	25000005	A1A-57368-00-00	GREASE VALVE CAP	2
30	14032531	A9A-58110-00-11	REAR FORK COMP. (RG 250)	1
31	14000007	A1A-58151-00-00	REAR FORK SPACER SLEEVE	1
32	14000005	A1A-58155-00-00	BUSHING CONTAIN OIL	2
33	14000004	A1A-58165-00-00	REAR FORK SEAL COVER	2
34	14000003	A1A-58175-00-00	RUBBER SLEEVE	1
35	14000019	95800-08016-02	FLANGE BOLT 8X16	8
36	12000001	94061-14000-01	FLANGE U NUT 14MM	2
37	14000057	A4A-26970-00-00	CHAIN TENSIONER ASSY.	1
38	14000045	A4A-26973-00-00	CHAIN TENSIONER BOLT	1
39	14032539	A9A-59507-00-10	NERF BAR CONNECTING ROD (RG 250)	1
40	14032541	95801-10048-03	FLANGE BOLT 10X48	4

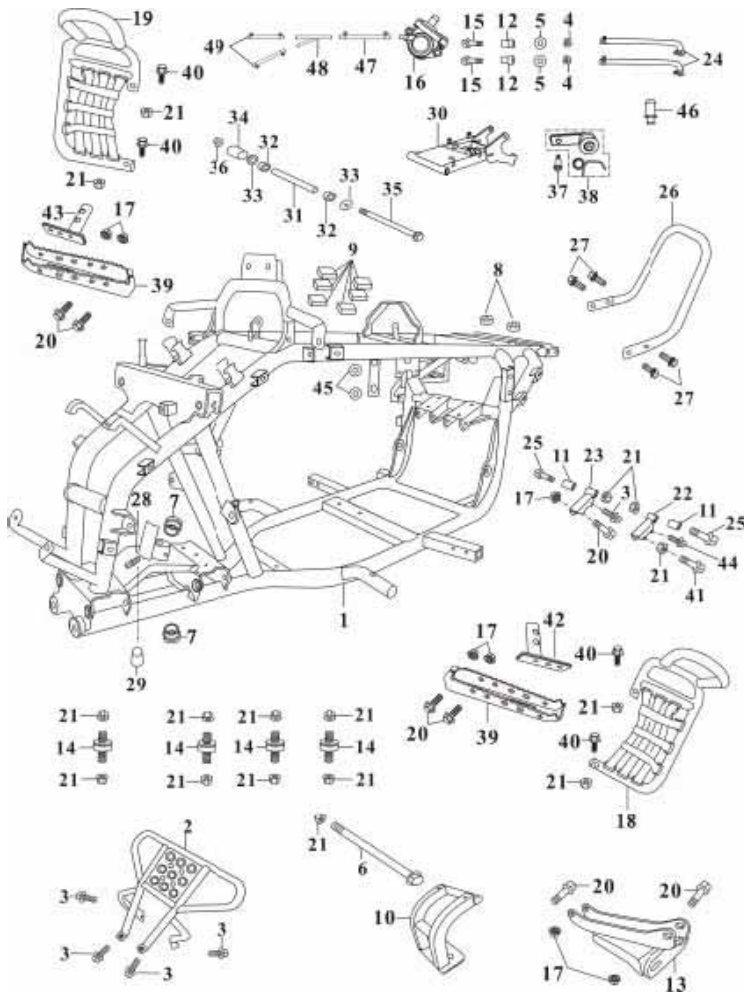

F1**FRAME BODY****R250CC**

ITEM	UNISON NO.	PARTS NO.	DESCRIPTION	QTY
41	14052522	95802-10054-01	FLANGE BOLT 10X54	1
42	14000038	A7A-59552-00-00	NERF BAR BRACKET,1	1
43	14000039	A7A-59562-00-00	NERF BAR BRACKET 2	1
44	14000058	95800-06016-02	FLANGE BOLT 6X16	4
45	14000044	A1A-52158-00-00	DAMPER,3	7
46	14052537	C2D-62815-00-00	HOSE JOINT	1
47	14052543	M9C-19498-00-00	VACUUM TUBE,2 (500M)	1
48	14052541	M5A-19487-00-00	THREE-WAY TUBE (Y TYPE)	1
49	14052542	M9C-19488-00-00	VACUUM TUBE,1 (100M)	2

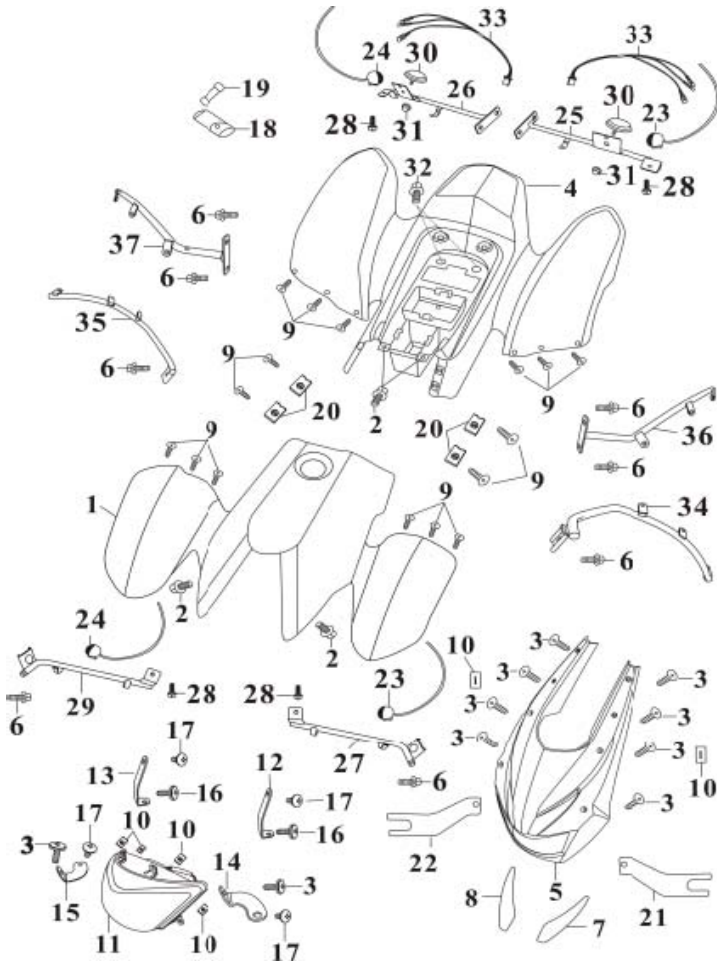

F2**SIDE COVER****R250CC**

ITEM	UNISON NO.	PARTS NO.	DESCRIPTION	QTY
1	15032501	A4A-73511-10-00	FRONT COVER (RG 250)	1
2	15000008	93404-06020-03	BOLT W/ WASHER 6X20	6
3	15032503	93900-05016-04	TAPPING SCREW 5X16	10
4	15032504	A4A-73521-10-00	REAR COVER (RG 250)	1
5	15032511	A5A-73515-00-00	HEAD COVER	1
6	15032506	A9D-35651-00-10	FR.FLASHER BRKT,1 (RG 250)	1
7	15032507	A9D-35652-00-10	FR.FLASHER BRKT,2 (RG 250)	1
8	15000007	A1A-73518-00-00	CLIP NUT 6MM	12
9	15000006	93530-06018-02	PAN HEAD SCREW 6X18	40
10	15000016	A1A-73519-00-00	CLIP NUT 5MM	4
11	15021505	A5A-35100-00-00	HEAD LIGHT ASSY.	1
12	15021506	A5A-35196-00-00	HEAD LIGHT STAY,1	1
13	15021507	A5A-35197-00-00	HEAD LIGHT STAY,2	1
14	15021508	A5A-35198-00-00	HEAD LIGHT STAY,3	1
15	15021509	A5A-35199-00-00	HEAD LIGHT STAY,4	1
16	15021510	93900-05012-04	TAPPING SCREW 5X12	2
17	15021511	93502-05010-02	PAN HEAD W/S 5X10	4
18	15021518	A4A-81110-00-00	TOOL KIT	1
19	27000017	A1A-81113-00-00	RUBBER	1
20	15032520	93502-05012-02	PAN HEAD W/S 5X10	2



F2

SIDE COVER

R250CC

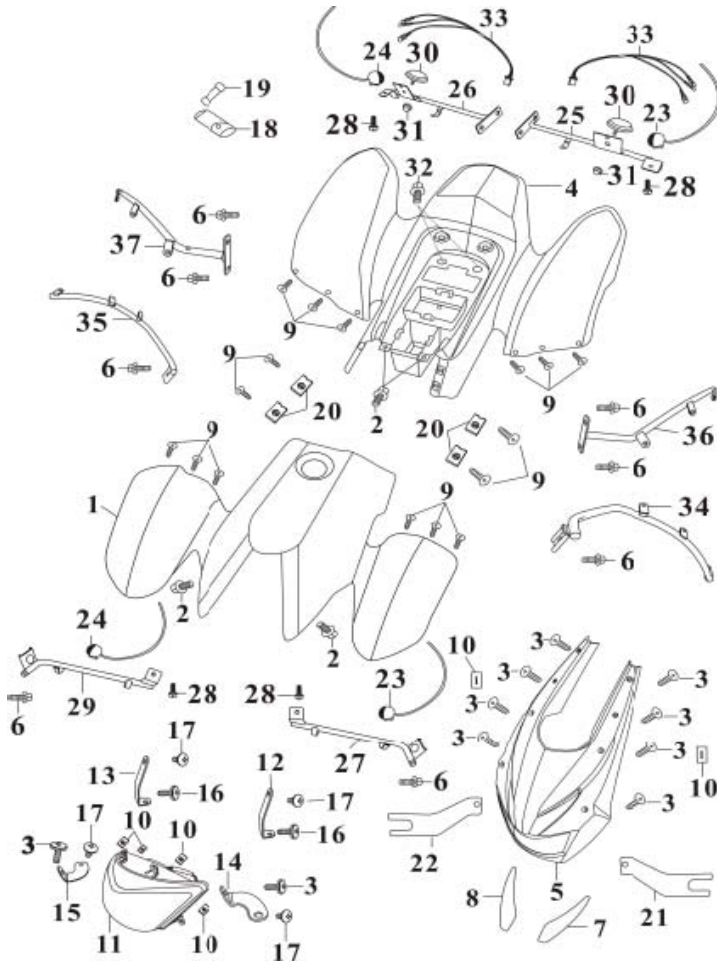

ITEM	UNISON NO.	PARTS NO.	DESCRIPTION	QTY
21	15032521	A5A-73596-00-10	BRACKET,1	1
22	15032522	A5A-73597-00-10	BRACKET,2	1
23	15032523	A3D-35620-00-00	FLASHER LIGHT ASSY.	2
24	15032524	A3D-35630-00-00	FLASHER LIGHT ASSY.	2
25	15032525	A5D-35658-00-20	RR.FLASHER BRKT,1	1
26	15032526	A5D-35659-00-20	RR.FLASHER BRKT,2	1
27	15032506	A9D-35651-00-10	FR.FLASHER BRKT,1 (RG 250)	1
28	15032520	93502-05012-02	PAN HEAD W/S 5X10	2
29	15032507	A9D-35652-00-10	FR.FLASHER BRKT,2 (RG 250)	1
30	14000056	A5D-35427-00-00	RR.REFLECTOR (E MARK) - R	2
31	15000014	94051-06000-01	FLANGE U NUT 6MM	14
32	15000013	93404-06016-03	BOLT W/WASHER 6X16	6
33	15032529	A4A-35667-00-00	FLASHER LIGHT CABLE	2
34	15032534	A4A-52121-00-10	FRONT COVER STABLE BRACKET,1	1
35	15032535	A4A-52122-00-10	FRONT COVER STABLE BRACKET,2	1
36	15032536	A4A-52123-00-10	REAR COVER STABLE BRACKET,1	1
37	15032537	A4A-52124-00-10	REAR COVER STABLE BRACKET,2	1
	15032591	N/A	RAGE 250 PLASTIC SET	

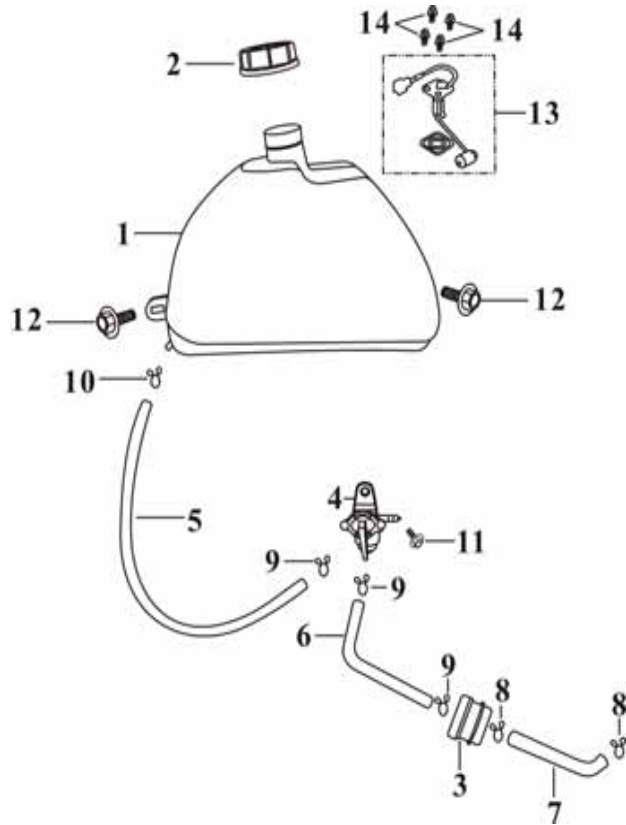

UNISON MOTORS

F3**FUEL TANK****R250CC**

ITEM	UNISON NO.	PARTS NO.	DESCRIPTION	QTY
1	16000021	A4A-62110-00-00	FUEL TANK COMP.	1
2	16000022	A4A-62210-00-00	FUEL TANK CAP	1
3	16000014	A1A-62410-00-00	FUEL FILTER ASSY.	1
4	16000023	A1B-62310-00-00	FUEL COCK ASSY.	1
5	16032505	A4A-62371-00-10	FUEL HOSE,1	2
6	16032506	A4A-62372-00-10	FUEL HOSE,2	1
7	16032507	A9A-62373-00-00	FUEL HOSE,3	1
8	16000016	94201-08085-00	CLIP	2
9	16000017	94201-12095-00	CLIP	5
10	16000018	94204-08110-00	CLIP	2
11	25000010	95800-06012-04	FLANGE BOLT 6X12	5
12	15000008	93404-06020-03	BOLT W/ WASHER 6X20	6
13	16000024	A4A-62510-00-00	SENDER UNIT ASSY.	1
14	16000025	93891-05014-04	BOLT W/WASHER 5X14	4

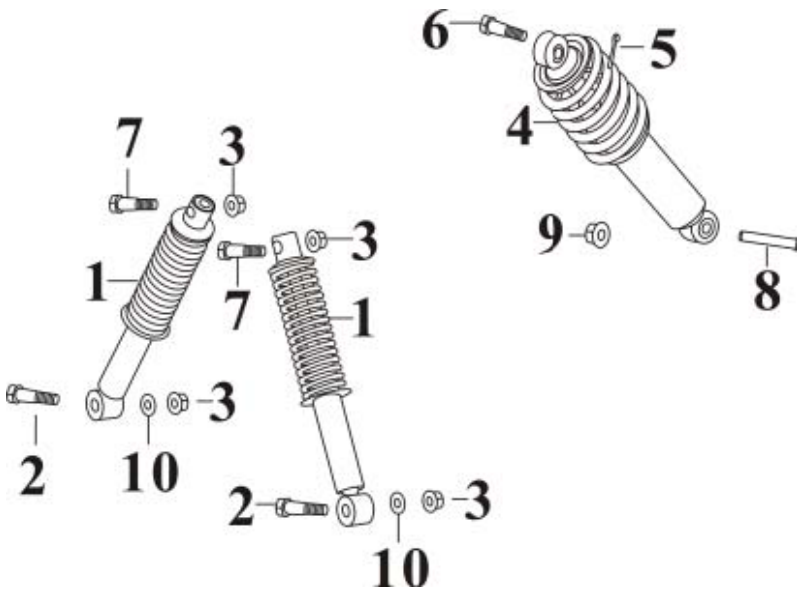

F4**SUSPENSION****R250CC**

ITEM	UNISON NO.	PARTS NO.	DESCRIPTION	QTY
1	17032501	A4A-57210-10-01	FR.SHOCK ABSORBER ASSY.	2
2	17000003	95801-10054-03	FLANGE BOLT 10X54	2
3	17000001	94061-10000-03	FLANGE U NUT 10MM	11
4	17032504	C2A-58210-10-00	RR. SHOCK ABSORBER ASSY.	1
5	44000005	94251-12221-00	SPLIT PIN 1.2X22	2
6	17000094	95827-10040-04	BOLT W/HOLE 10X40	1
7	17000011	95802-10045-03	FLANGE BOLT 10X45	2
8	17032508	95802-12078-03	FLANGE BOLT 12X78	1
9	14000012	94061-12000-03	FLANGE U NUT 12MM	2
10	10000002	94101-10185-27	PLATE WASHER 10MM	2

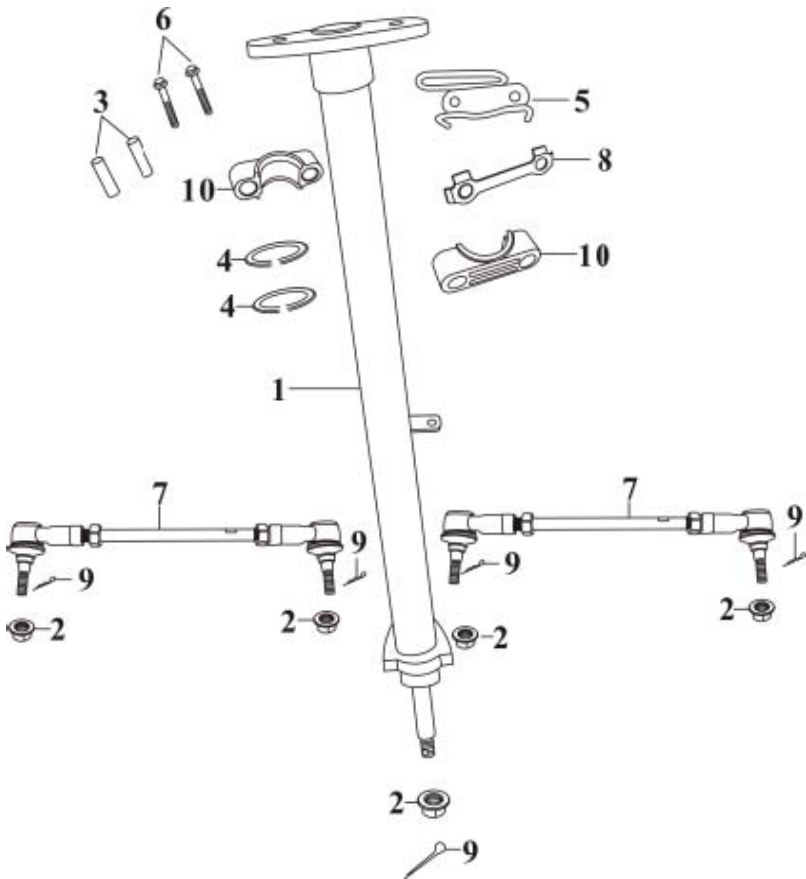

F5**STEERING****R250CC**

ITEM	UNISON NO.	PARTS NO.	DESCRIPTION	QTY
1	18032501	C2D-72140-00-00	SHAFT STEERING	1
2	17000001	94061-10000-03	FLANGE U NUT 10MM	11
3	18000016	A4A-72141-00-00	HOLDER COLLAR	2
4	18032504	A4A-72167-00-00	DUST SEAL	2
5	18000024	A4A-72156-00-00	BRAKE CABLE SEAT	1
6	18032506	92000-08060-01	HEX. BOLT 8X60	2
7	18052507	C2A-72143-00-00	STEERING TIE.ROD ASSY,1	2
8	18000021	A4A-72157-00-00	TONGUED WASHER	1
9	18000015	94201-22305-03	SPLIT PIN 2.2X30.5	4
10	18000020	A4A-72146-00-00	HOLDER, STEERING SHAFT	2

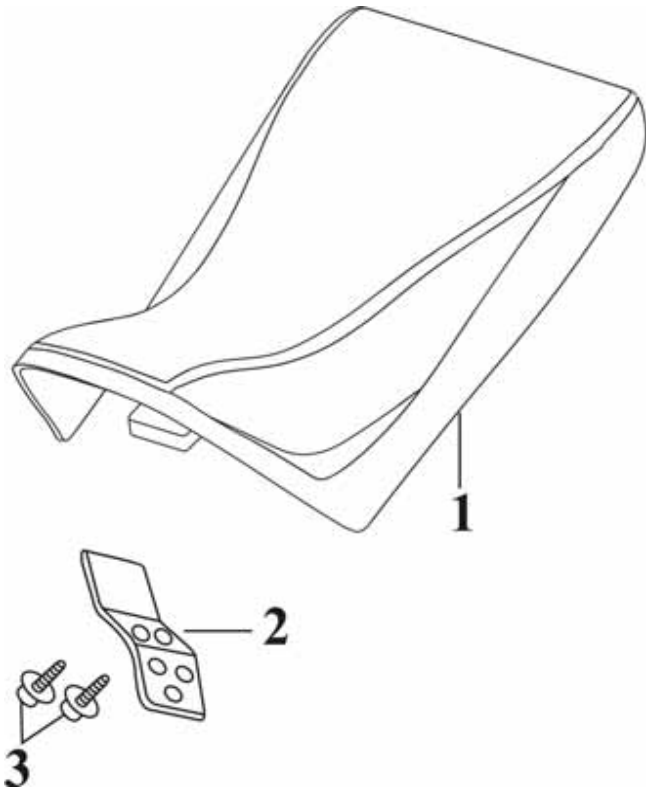

F6**SEAT ASSEMBLY****R250CC**

ITEM	UNISON NO.	PARTS NO.	DESCRIPTION	QTY
1	19032501	A4A-76111-00-10	SEAT ASSY.	1
2	19000003	A4A-76162-00-00	BRACKET	1
3	19000007	93900-04012-04	TAPPING SCREW 4X12	2

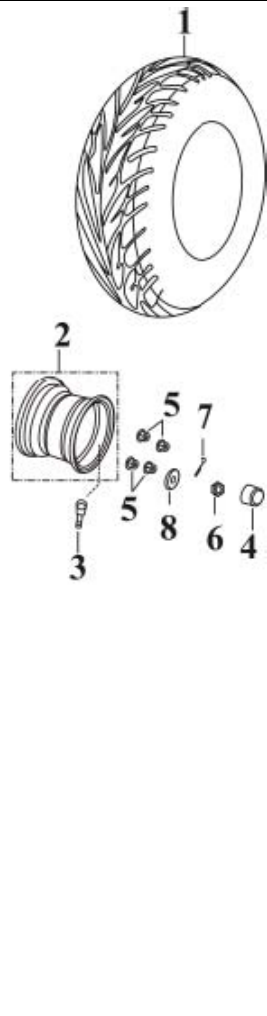

F7**FRONT WHEEL****R250CC**

ITEM	UNISON NO.	PARTS NO.	DESCRIPTION	QTY
1	20052501	A5D-53311-00-00	TIRE 21X7-10	2
2	20032502	A4A-53210-00-03	WHEEL COMP.10X5.5 (RG 250)	2
3	20000006	A1A-53322-00-00	RIM VALVE	2
4	20000008	A1A-53268-00-00	RUBBER CAP	2
5	20000013	A4A-54267-00-00	CONE NUT 10MM	8
6	20000011	A4A-54266-00-00	CASTLE NUT 14MM	2
7	20032513	94201-30430-03	SPLIT PIN 3.0X43	2
8	22000004	A1A-54256-00-00	WASHER	2

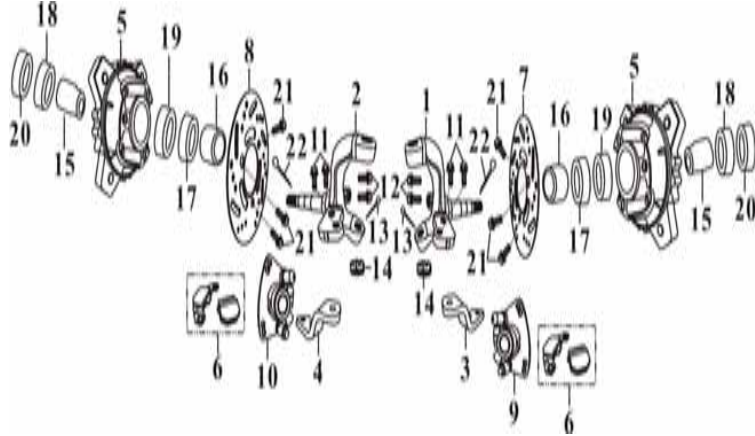

F8**FRONT BRAKE****R250CC**

ITEM	UNISON NO.	PARTS NO.	DESCRIPTION	QTY
1	21032501	A4A-72144-00-01	KNUCKLE,1	1
2	21032502	A4A-72154-00-01	KNUCKLE,2	1
3	21032503	A4A-72185-00-01	STEERING BRKT,1	1
4	21032504	A4A-72195-00-01	STEERING BRKT,2	1
5	21032505	A5A-55480-00-00	FRONT WHEEL DRUM ASSY.	2
6	24000021	A3D-56023-00-00	BRAKE PADS	2
7	21032507	A5A-55003-00-00	FRONT BRAKE DISK L	1
8	21032508	A5A-55004-00-00	FRONT BRAKE DISK R	1
9	21032509	A5A-55010-00-01	FRONT BRAKE CALIPER L	1
10	21032510	A5A-55020-00-01	FRONT BRAKE CALIPER R	1
11	21000025	95807-10030-02	FLANGE BOLT 10X30	4
12	14000010	95800-08020-02	FLANGE BOLT 8X20	4

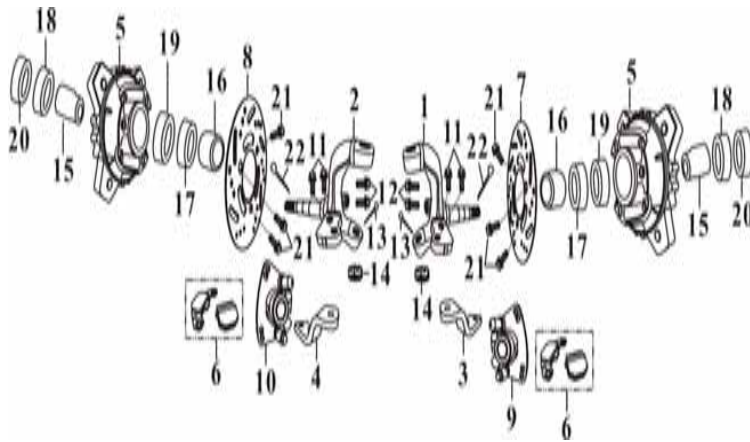

F8**FRONT BRAKE****R250CC**

ITEM	UNISON NO.	PARTS NO.	DESCRIPTION	QTY
13	18000015	94201-22305-03	SPLIT PIN 2.2X30.5	4
14	20000007	A1A-53266-00-00	CASTLE NUT 12MM	2
15	21032515	A4A-55446-00-00	COLLAR	2
16	20032508	A4A-55456-00-00	COLLAR 23X16X8.5	2
17	20032509	91201-23035-70	OIL SEAL 23X35X7	2
18	20032510	96120-06004-20	BALL BEARING 6004 LU	2
19	20011504	91201-23035-70	OIL SEAL 23X35X7	2
20	07000035	91201-27042-70	OIL SEAL 27X42X7	2
21	21032521	A5A-55037-00-00	SOCKET BOLT	6
22	18000003	94201-18213-03	SPLIT PIN 1.8X21.3	4

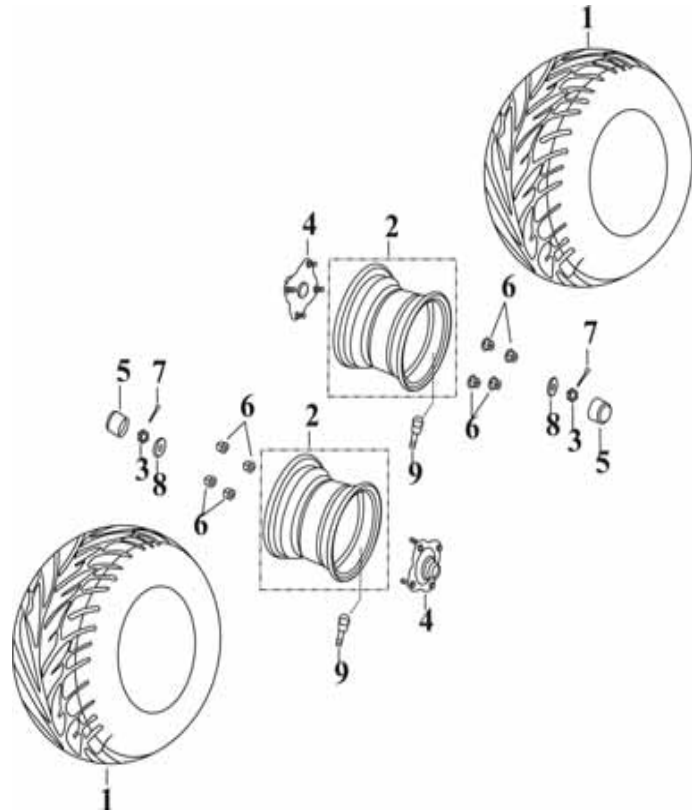

F9**REAR WHEEL****R250CC**

ITEM	UNISON NO.	PARTS NO.	DESCRIPTION	QTY
1	22032501	A4A-54311-00-02	TIRE 22X10-10	2
2	22032502	A4A-54210-00-02	WHEEL COMP	2
3	20000011	A4A-54266-00-00	CASTLE NUT 14MM	2
4	22032504	A4A-54223-00-01	REAR WHEEL CONNECTER	2
5	20000008	A1A-53268-00-00	RUBBER CAP	2
6	20000013	A4A-54267-00-00	CONE NUT 10MM	8
7	18032509	94201-30550-03	SPLIT PIN 3.0X55	2
8	22000004	A1A-54256-00-00	WASHER	2
9	20000006	A1A-53322-00-00	RIM VALVE	2



F10

HANDLE BAR

R250CC

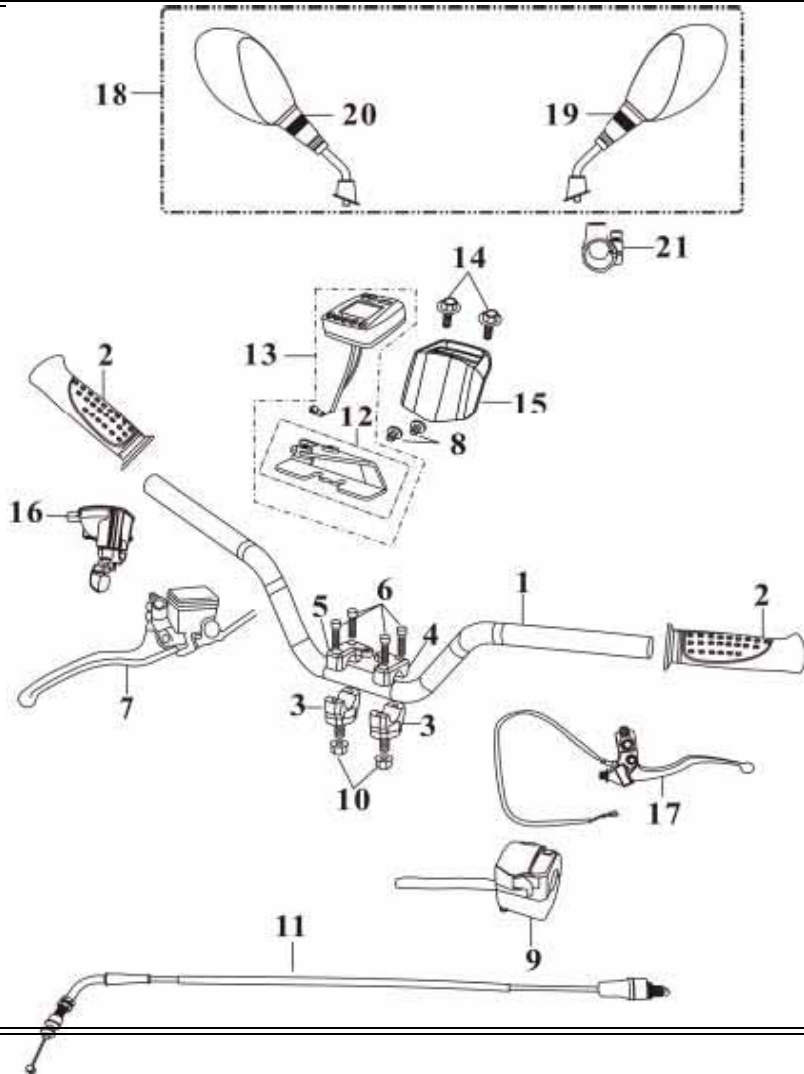

ITEM	UNISON NO.	PARTS NO.	DESCRIPTION	QTY
1	23000028	A4A-72110-00-00	HANDLE COMP.	1
2	23000001	A1A-72251-00-01	GRIP	2
3	23032503	A1A-72222-00-10	LOWER HANDLE BAR CLAMP ASSY.	2
4	23000005	A1A-72225-00-00	HANDLE HOLDER COVER,1	1
5	23000006	A1A-72235-00-00	HANDLE HOLDER COVER,2	1
6	23000003	96700-06025-02	SOCKET BOLT 6X25	4
7	23052507	A5A-55000-00-00	R. HANDLE MASTER CYC. ASSY.	1
8	27052506	95800-06014-04	PAN HEAD SCREW 8X14	1
9	23032509	A4A-37700-00-01	LEFT HANDLE SWITCH ASSY. (RG 250)	1
10	17000001	94061-10000-03	FLANGE U NUT 10MM	11
11	23052511	C2A-68410-00-00	THROTTLE CABLE ASSY.	1
12	23052512	A4A-34136-00-02	SPEEDOMETER BRACKET	1
13	23052513	C2A-34110-00-00	SPEEDOMETER ASSY.	1
14	25000027	95800-06012-02	FLANGE BOLT 6X12	2
15	23032516	A4A-72311-00-00	HANDLE COVER (RG 250)	1
16	23052516	A5A-37840-00-00	THROTTLE LEVER ASSY.	1
17	25052522	A4A-37750-00-00	LEFT LEVEL HANDLE ASSY	1
18	23052518	A5D-72500-00-00	REAR VIEW MIRROR SET	1
19	23052519	A5D-72510-00-00	FR. REAR VIEW MIRROR	1
20	23052520	A5D-72520-00-00	FL. REAR VIEW MIRROR	1
21	25052523	A4A-72516-00-00	REAR VIEW MIRROR BRKT	1



F11

REAR DISC ASSEMBLY

R250CC

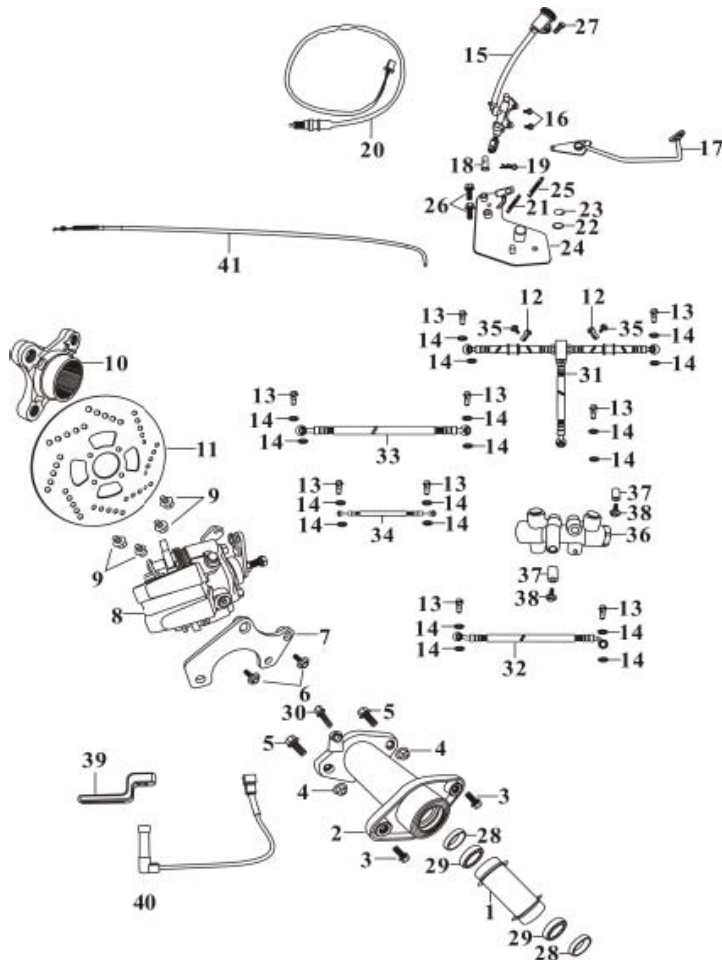

ITEM	UNISON NO.	PARTS NO.	DESCRIPTION	QTY
1	44000014	A5A-54522-00-00	SPACER TUBE	1
2	44021502	A5A-54521-00-10	REAR WHEEL AXLE SEAT	1
3	31000001	95800-12028-02	FLANGE BOLT (BLACK)	2
4	44000013	94060-12000-03	FLANGE NUT 12MM	2
5	31032505	92000-12050-02	BOLT 12X50 (RG 250)	2
6	31032506	95701-10025-0A	FLANGE BOLT10X25 (RG 250)	8
7	44000015	A5A-56022-00-00	CALIPER STAY	1
8	31032508	A5A-56020-00-00	CALIPER ASSY (RG 250)	1
9	44000016	A5A-56037-00-00	PAN HEAD SOCKET BOLT	4
10	44000017	A5A-56034-00-00	BRAKE DISC STAY	1
11	44000018	A5A-56033-00-00	BRAKE DISC	1
12	31032512	A5A-55365-00-00	HOSE CLAMP (RG 250)	2
13	31032513	A1A-56027-00-10	HOSE BOLT (RG 250)	8
14	31000014	94101-10143-50	PLATE WASHER	16
15	31000015	A3D-56050-00-00	MASTER CYLINDER,2	1
16	44000007	95800-08030-02	FLANGE BOLT 8X30	2
17	31032517	A5A-59610-00-10	BRAKE PEDEL COMP. (RG 250)	1
18	44045101	A9D-59675-00-00	PIN 1	1
19	44000005	94251-12221-00	SPLIT PIN 1.2X22	2
20	44000019	A3D-59670-00-00	STOP SWITCH ASSY.	1



F11

REAR DISC ASSEMBLY

R250CC

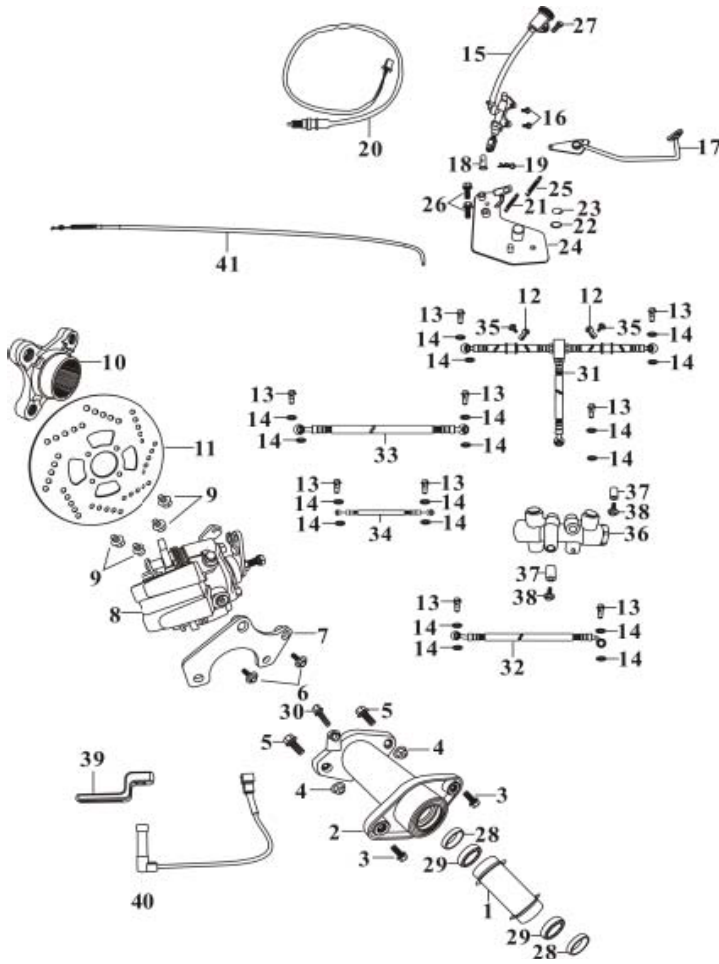

ITEM	UNISON NO.	PARTS NO.	DESCRIPTION	QTY
21	31032521	A5A-59652-00-00	TENSION SPRING,1	1
22	44000009	A5A-59657-00-00	WASHER 19X25X2.0	1
23	04000011	94511-12190-00	CIR-CLIP 19MM	2
24	31000015	A5A-56035-00-10	MASTER CYLINDER BRKT	1
25	44000010	A5A-59653-00-10	TENSION SPRING,2	1
26	14000016	95800-08014-02	FLANGE BOLT 8X14	8
27	07000010	96001-06020-01	FLANGE BOLT 6X20	2
28	44000020	91201-42062-08	OIL SEAL 42X62X08	2
29	44000021	96120-06007-20	BALL BEARING 6007Z	2
30	14000016	95800-08014-02	FLANGE BOLT 8X14	8
31	31032531	A9D-56043-00-00	BRAKE HOSE,1	1
32	31032532	A9D-56053-00-00	BRAKE HOSE,2	1
33	31032533	A9D-56063-00-00	BRAKE HOSE,3	1
34	31032534	A9D-56073-00-00	BRAKE HOSE,4	1
35	39000009	96001-06032-03	FLANGE BOLT 6X32	1
36	31032536	A9D-55030-00-00	DIVERSION VALVE	1
37	31032537	A9D-55035-00-00	COLLER	2
38	07000015	96001-06065-02	FLANGE BOLT 6X65	2
39	25052519	A4A-34116-00-00	METER SENSOR	1
40	31032538	A5A-6821-00-00	REAR BRAKE CABLE ASSY.	1



F12

SWING ARM / FOOTREST / FEND BAR

R250CC

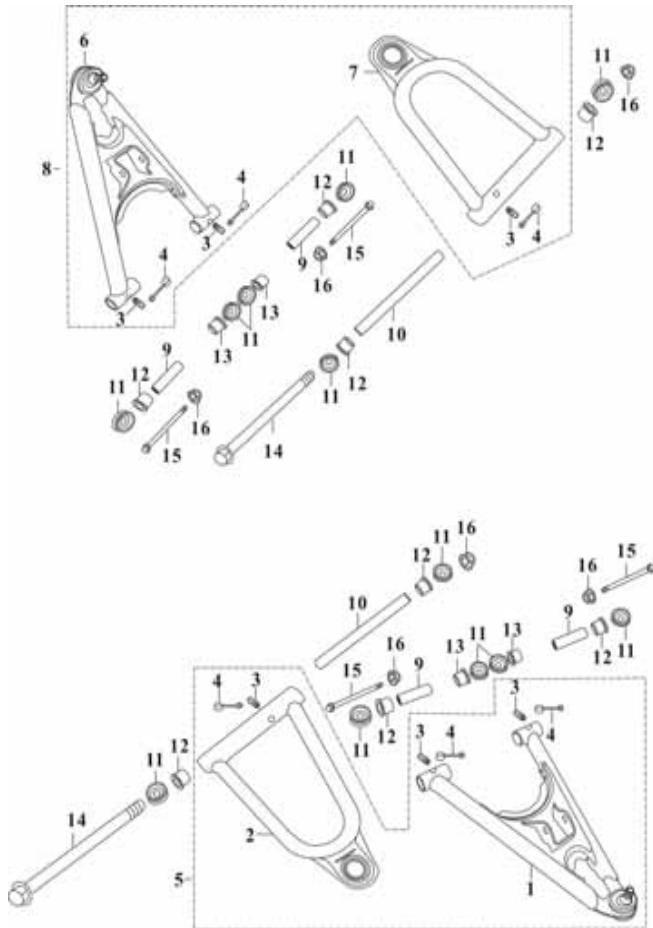

ITEM	UNISON NO.	PARTS NO.	DESCRIPTION	QTY
1	25032501	A9A-57411-00-00	FRONT SWING ARM,1	1
2	25032502	A9A-57412-00-00	LEFT UP SWING ARM	1
3	25000011	A1A-57367-00-00	GREASE VALVE	6
4	25000005	A1A-57368-00-00	GREASE VALVE CAP	2
5	25032505	A9A-57410-00-00	FRONT SWING ARM ASSY.,1	1
6	25032506	A9A-57421-00-00	FRONT SWING ARM,2	1
7	25032507	A9A-57422-00-00	RIGHT UP SWING ARM	1
8	25032508	A9A-57420-00-00	FRONT SWING ARM ASSY.,2	1
9	25000012	A4A-57427-00-00	DISTANCE COLLAR,1	4
10	25000018	A4A-57428-00-00	DISTANCE COLLAR, 2	2
11	25000019	A4A-57419-00-00	DUST SEAL COVER	12
12	25000020	A4A-57447-00-00	BUSH,1	8
13	25000021	A4A-57448-00-00	BUSH,2	4
14	14000034	A4A-53511-00-00	FLANGE BOLT 10X198	2
15	25000025	95800-10080-03	FLANGE BOLT 10X80	4
16	17000001	94061-10000-03	FLANGE U NUT 10MM	11



F13

MUFFLER ASSEMBLY

R250CC

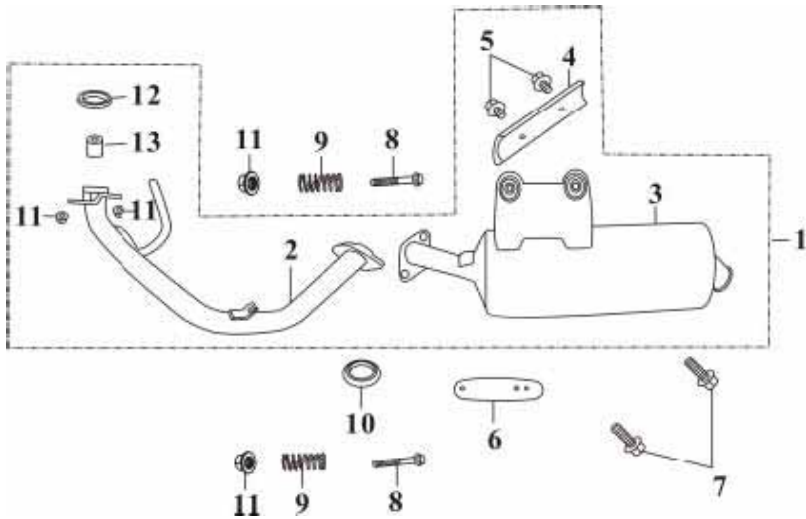

ITEM	UNISON NO.	PARTS NO.	DESCRIPTION	QTY
1	26032512	C2D-28200-00-00	EXHAUST PIPE ASSY.	1
2	26032513	C2D-28220-00-00	FR PIPE COMP.	1
3	26032514	C2D-28230-00-00	RR PIPE COMP.	1
4	26000004	A1A-28112-00-00	MUFFLER PROTECTOR,2	1
5	26032505	93891-06007-03	PAN HEAD W/S 6X7	2
6	26052504	A9A-28111-00-00	EXHAUST PIPE PROTECTOR,1	1
7	26032507	95802-08032-02	FLANGE BOLT 8X32	2
8	26032506	A9A-28116-00-00	EXHAUSE PIPE FLANGE BOLT (RG 250)	2
9	26032509	A9A-28136-00-00	EXHAUSE PIPE SPRING	2
10	43002524	A9A-28131-00-00	EXHAUST PIPE GASKET	1
11	14000020	94051-08000-03	FLANGE U NUT 8MM	6
12	43002524	SEA-18292-00	EXHAUST PIPE GASKET	1
13	26052513	C2A-28227-00-00	COLLAR 15X8.5X15L	1



F14

ELECTRICAL PARTS

R250CC

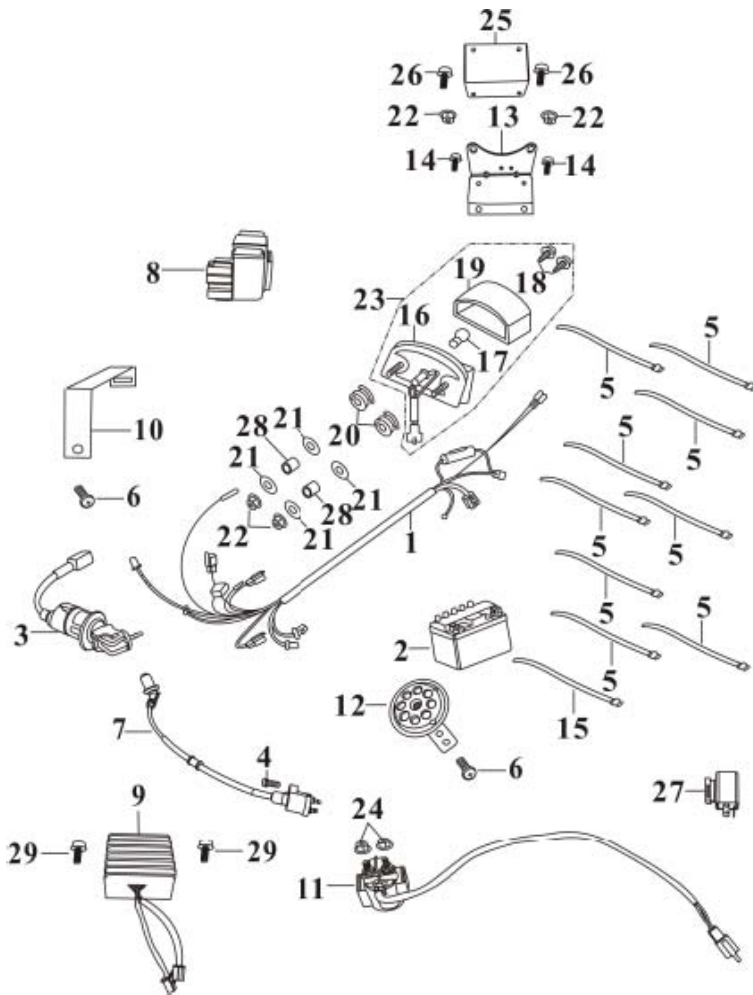

ITEM	UNISON NO.	PARTS NO.	DESCRIPTION	QTY
1	27032511	C2A-33610-00-00	WIRE HARNESS ASSY.	1
2	27032502	A9A-33410-00-00	BATTERY ASSY. (RG 250)	1
3	27032503	A9D-66210-00-00	MAIN SWITCH ASSY. (RG 250)	1
4	27000029	93500-05022-02	PAN HEAD SCREW 5X22	1
5	27000039	94402-02502-01	BAND 250	10
6	25000010	95800-06012-04	FLANGE BOLT 6X12	5
7	27052505	UCA-30510-00	IGNITION COIL ASSY.	1
8	43002514	SE1-30400-00	CDI	1
9	27052509	SEA-31600-00	REGULATOR/RECTIFIER	1
10	43002512	SEA-3151A-00	FIXED BOARD ASSY. OF BATTERY SEAT	1
11	27000045	M4A-38310-00-00	STARTER RELAY ASSY.	1
12	27000010	A1A-38210-00-00	HORN	1
13	27000022	A4A-35437-00-10	TAIL LIGHT BRACKET	1
14	14000016	95800-08014-02	FLANGE BOLT 8X14	8
15	27000002	94404-03001-01	BAND 300MM	1
16	27000011	A1A-35411-00-00	TAIL LIGHT BASE	1
17	27000035	A1A-35451-00-00	BULB 12V-21/5W	1
18	27000012	93910-04038-03	TAPPING SCREW 4X38	2
19	27000013	A1A-35412-00-00	TAIL LIGHT LENS	1
20	14000044	A1A-52158-00-00	DAMPER,3	7



F14

ELECTRICAL PARTS

R250CC

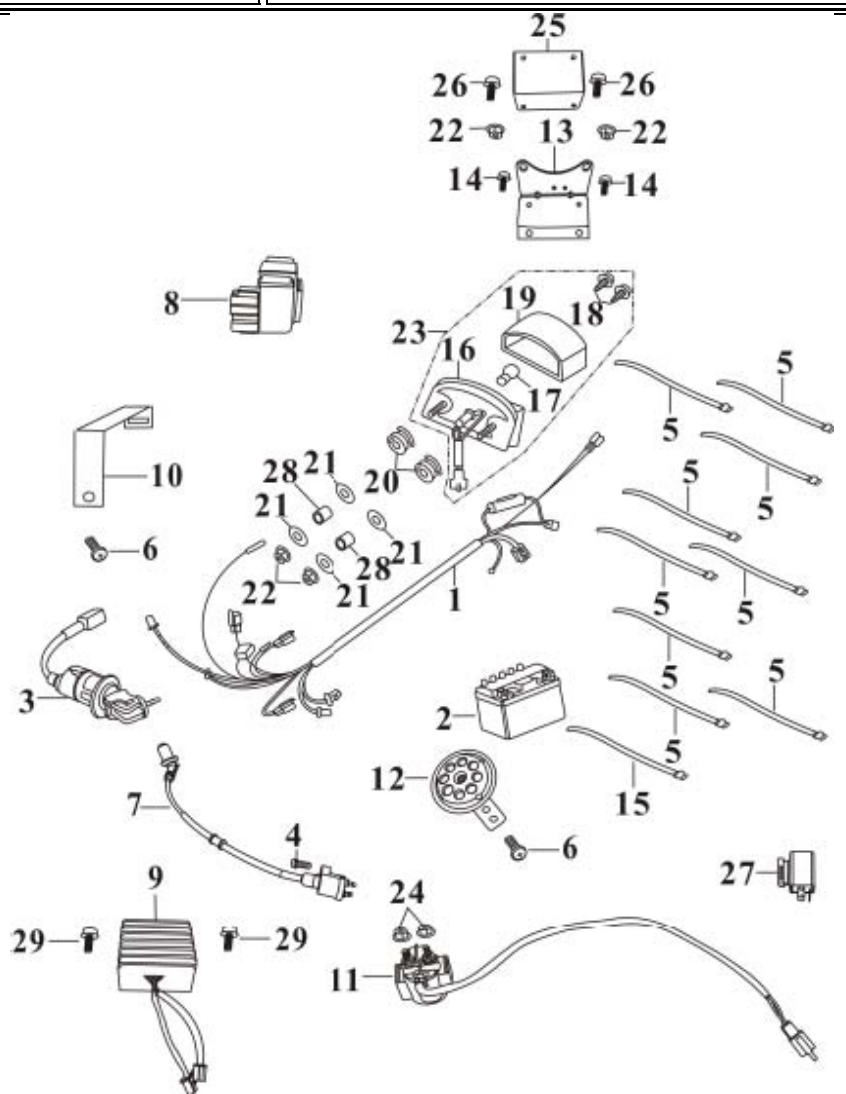

ITEM	UNISON NO.	PARTS NO.	DESCRIPTION	QTY
21	09000002	94101-06193-00	PLATE WASHER 6MM	4
22	26000020	94050-06000-01	FLANGE NUT 6MM	2
23	27032522	A1A-35400-00-00	TAIL LIGHT ASSY.	1
24	26000020	94050-06000-01	FLANGE NUT 6MM	2
25	27032512	A4A-74251-00-10	LICENSE BRACKET	1
26	14000058	95800-06016-02	FLANGE BOLT 6X16	4
27	27052517	A3D-38110-00-00	FLASHER RELAY	1
28	27000021	M5A-16567-00-10	COLLER	3
29	07000014	96000-06025-02	FLANGE BOLT 6X25	8



F15

REAR WHEEL AXLE

R250CC

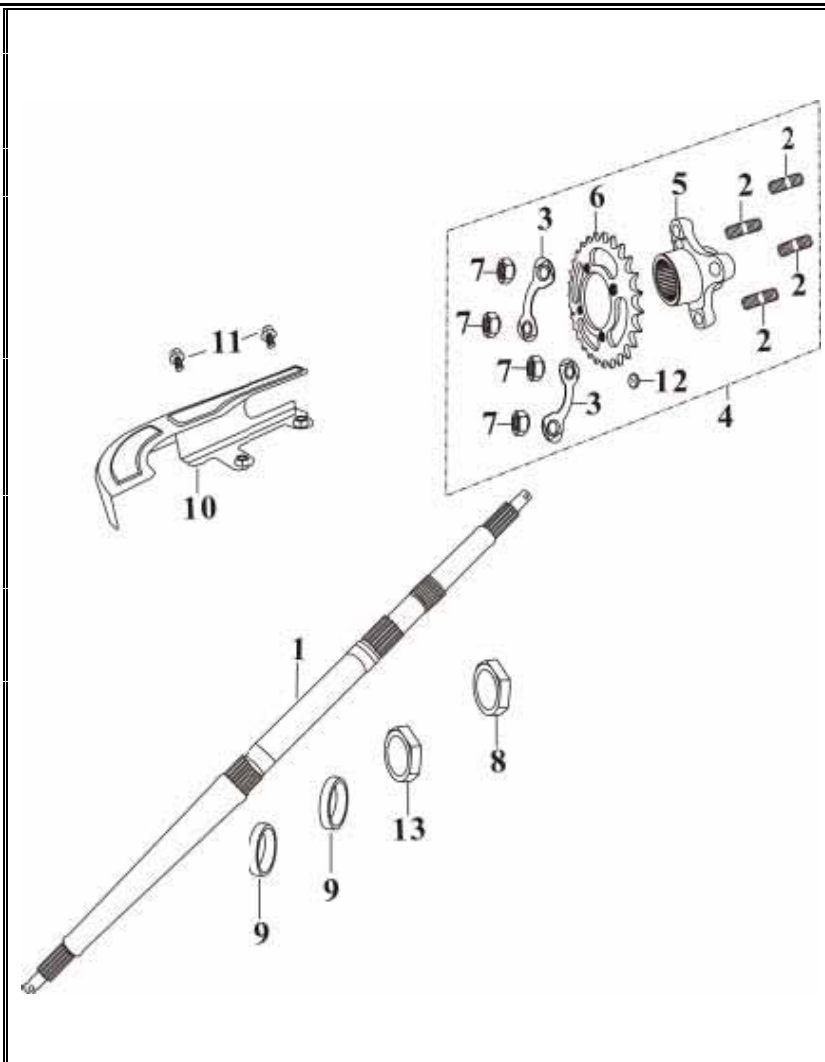

ITEM	UNISON NO.	PARTS NO.	DESCRIPTION	QTY
1	28000021	A5A-54511-00-10	REAR WHEEL AXLE	1
2	28000008	A4A-26957-00-00	STUD BOLT 10MM	4
3	28000009	A4A-26958-00-00	TOUNGED WASHER	2
4	02000007	A4A-26950-00-00	SPROCKET ASSY. (RG 250)	1
5	28000010	A4A-26955-00-00	SPROCKET HOLDER	1
6	28000011	A4A-26930-00-00	SPROCKET	1
7	29000011	94001-08000-03	HEX. NUT 8MM	6
8	28000016	A4A-54524-00-10	HEX NUT M33	2
9	28000019	A5A-54523-00-00	COLLAR	1
10	28000020	A4A-26942-00-00	CHAIN CASE,2	1
11	29000003	95800-08012-02	FLANGE BOLT 8X12	4
12	28032512	A4A-34126-00-00	SENSOR,1	1
13	28032513	A4A-54524-00-01	HEX. NUT M33	1

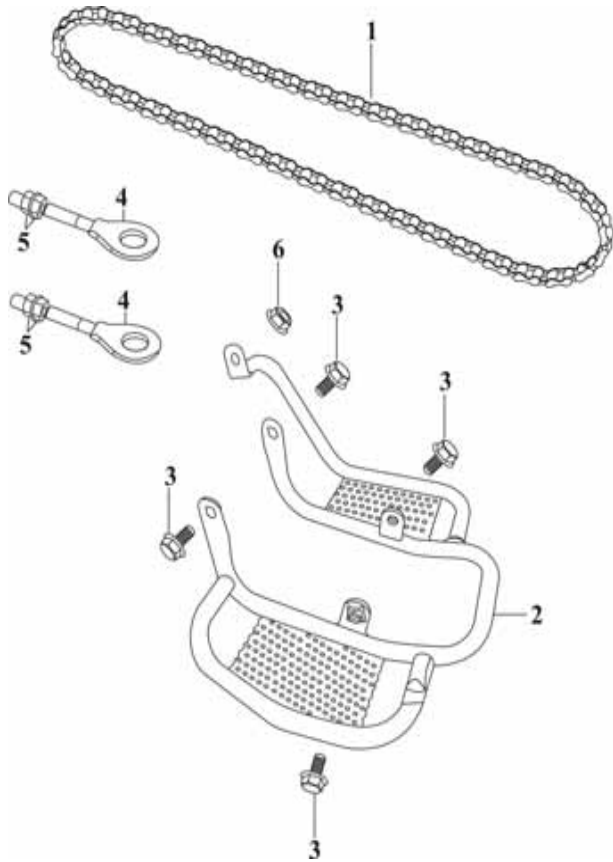

F16**CHAIN****R250CC**

ITEM	UNISON NO.	PARTS NO.	DESCRIPTION	QTY
1	29032501	A9A-26960-00-00	DRIVE CHAIN 520x90	1
2	29032502	A4A-56443-00-10	PROTECTOR COVER	1
3	14000019	95800-08016-02	FLANGE BOLT 8X16	8
4	29000012	A4A-56471-00-00	CHAIN ADJUSTER	2
5	29000011	94001-08000-03	HEX. NUT 8MM	6
6	14000020	94051-08000-03	FLANGE NUT 8MM	6



F17

COOLER

R250CC

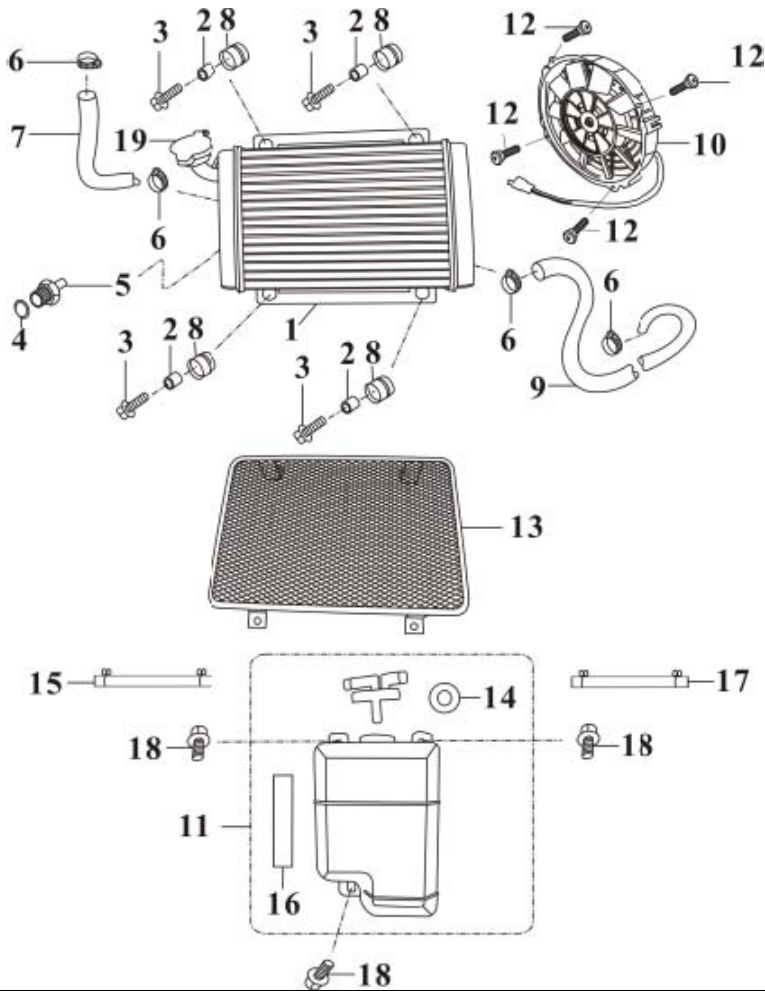

ITEM	UNISON NO.	PARTS NO.	DESCRIPTION	QTY
1	52032506	M9C-16510-00-00	RADIATOR	1
2	27000021	M5A-16567-00-10	COLLER	4
3	47052503	95800-06025-02	FLANGE BOLT 6X25	4
4	47052504	91305-35140-00	O-RING14X3.5	1
5	52032505	M9C-16520-00-00	TERMINAL SWITCH	1
6	47052506	M9C-16534-00-00	CLAMP (M-1 25MM)	8
7	47052507	M9C-16533-00-00	HOSE,2	1
8	14000044	A1A-52158-00-00	DAMPER,3	7
9	52032503	M9C-16532-00-00	HOSE,1	1
10	52032504	M9C-16610-00-00	ELECTRIC FAN (8")	1
11	47052512	M9C-16710-00-00	SEC.WATER TANK	1
12	07000025	93500-05010-02	PAN HEAD SCREW 5X10	4
13	52032502	M9C-16568-00-00	RADIATOR PROTECTOR	1
14	47052510	M9C-16725-00-00	WATER TANK PACKING	1
15	47052513	M9C-16732-00-00	SEC.WATER TANK HOSE,1	1
16	47052511	M9C-16733-00-00	SEC.WATER TANK HOSE,2	1
17	47052514	M9C-16731-00-00	SEC.WATER TANK VENTILATOR	1
18	15000008	93404-06020-03	BOLT W/ WASHER 6X20	6
19	52032501	M9C-16522-00-00	RADIATOR COVER	1

